



1.6

V93N SERIES

Swash-plate Type Axial Piston Variable Displacement Double Pump

V93N variable axial piston double pump is designed for the high pressure open circuit.. Increase displacement and have a wider range of applications.

Displacement (cc/rev):	145×2	375×2
Nominal pressure (bar):	380	420
Max. pressure (bar):	420	460



Contents

Technical Data	02
Type introduction	03-04
V93N 145 Type	
• Control principle	05
• Installation size	06-08
V93N 375 Type	
• Control principle	09
• Installation size	10-12

Features

- Variable axial piston double pump design for the open circuit.
- High working pressure (460 bar) and long lifetime.
- Newly developed control valve with built-in high-precision filter to enhance anti pollution capability.
- Horizontal piston design, short longitudinal length, large diameter variable piston, faster variable response speed.
- The dual PTO structure provides more power output interfaces. The variable speed ratio of the power take-off improves the boosting effect and maximizes the performance of the auxiliary pump.
- The booster impeller enhances the oil suction capacity of the entire pump and increases the operating speed of the pump. Simultaneously equipped with a booster impeller and a power take-off, it can save the cost of the main engine transfer case.

Technical data

Size		V93N 145	V93N 375
Displacement(cc/rev)		145×2	375×2
Speed	Rated speed (rpm) ¹	2200	1600
	Maximum speed (rpm) ²	2500	1700
Pressure	Rated pressure (bar)	380	420
	Maximum pressure (bar)	420	460
Maximum torque (N.m) @Vgmax and Δp=380bar		1754	4538
Case volume (L)		3	13
Suction port pressure (abs bar)		0.8 ~ 2	
Drain pressure (bar)		1	
Max. drain pressure (bar)		3 ⁴	
Mass (Kg)		127	400
Temperature range (°C)		-20 ~ 95	
Hydraulic fluid viscosity range (mm ² /s)		10 ~ 1000 ³ (optimum viscosity range 16 ~ 36)	

1 Steady state suction pressure should be 0 bar and above (at normal condition);

2 If suction pressure less than 0 bar, Boost pressure should be required;

3 In case of 200-1000mm²/s, please allow system to warm up before using machine;

4.The pressure at the drain port is 1.2 bar (18 psi) higher than the inlet pressure at port S, but not higher than P_{Lmax}.

Type introduction

V93N	375	T	V	R	E1	/	G	J7	K0	N	G	M	S
①	②	③	④	⑤	⑥		⑦	⑧	⑨	⑩	⑪	⑫	⑬

Product series

①	Double pump, variable swash-plate design, open circuit	V93N
---	--	------

Displacement

②	Displacement cc/rev	145	375
---	---------------------	-----	-----

Structure type

③		145	375	Code
	Structure type	Tandem double pump	●	●

Seals

④		145	375	Code
	FKM	●	●	V

Direction rotation

⑤		145	375	Code
	Clockwise	●	●	R
	Counter-clockwise		●	L

Control type

⑥		145	375	Code	
	Electric proportional displacement	Pilot operated proportional displacement control (positive control), 24V	●		E1
		Pilot-operated electro-proportional displacement control, pressure cut-off, positive control, 24V		●	F1

Mounting flange

⑦		145	375	Code
	SAE J617 N0.3 flywheel flange, see "Installation size" (Axial length : narrow)	●		A
	315 B8 HW ISO 3019-2		●	G

Type introduction

Input shaft

		145	375	Code
⑧	JIS B 1603 47.5×17×2.5	●		J2
	JIS B 1603 40×14×2.5	●		J3
	DIN 5480×W70×3×22×9g		●	J7
	ANIS 21T-8/16DP		●	X1

Through drive and pilot pump

		145	375	Code
⑨	None	●	●	N
	With pilot gear pump and pressure relief valve (only for none through drive)	●	●	K0

PTO Power port drive

		145	375	Code
⑩	No pressurization, no force extractor	●	●	N
	Pressurization, force extractor		●	T
	Pressurization, no force extractor		●	H

Connection type (except inlet and outlet port)

		145	375	Code
⑪	BSPP G thread, JIS B2351	●	●	G

Thread type of Flange Port

		145	375	Code
⑫	Metric thread	●	●	M

Standard / special version

		145	375	Code
⑬	Standard version	●	●	None
	Special version	○	○	S

Remark: ● = Available; ○ = On request

V93N 145 Control principle

· E1 Electro-proportional displacement control principle

Electro-proportional displacement control: With pilot-pressure-related control, the pump displacement is adjusted in proportion to the pilot pressure. Basic position without pilot signal is $V_g \text{ min}$, which includes the mechanically depressurized basic position $V_{g\text{min}}$. With increasing pilot pressure the pump swivels to a larger displacement. The necessary control power is taken from the operating pressure or the external control pressure applied to port P. If the pump is to be adjusted from the zero basic setting or from a low operating pressure, port P must be supplied with an external control pressure of at least 30 bar, maximum 50 bar.

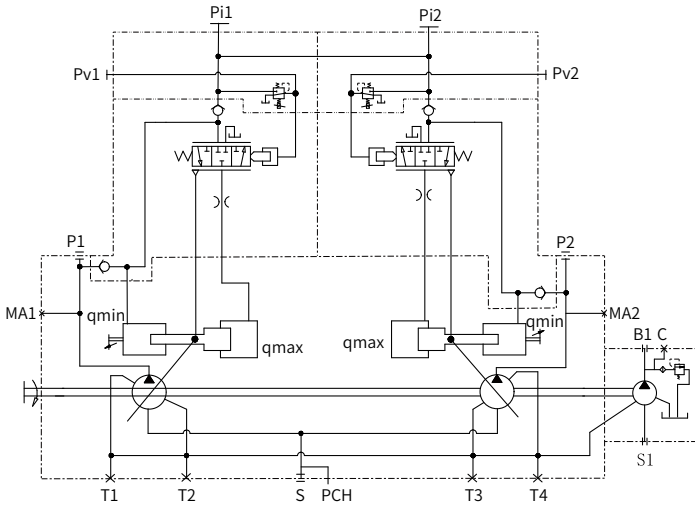

Note:

When ordering, please provide the information as below:

- Working pressure
- Maximum flow
- Minimum flow

Installation size

V93N 145 Type

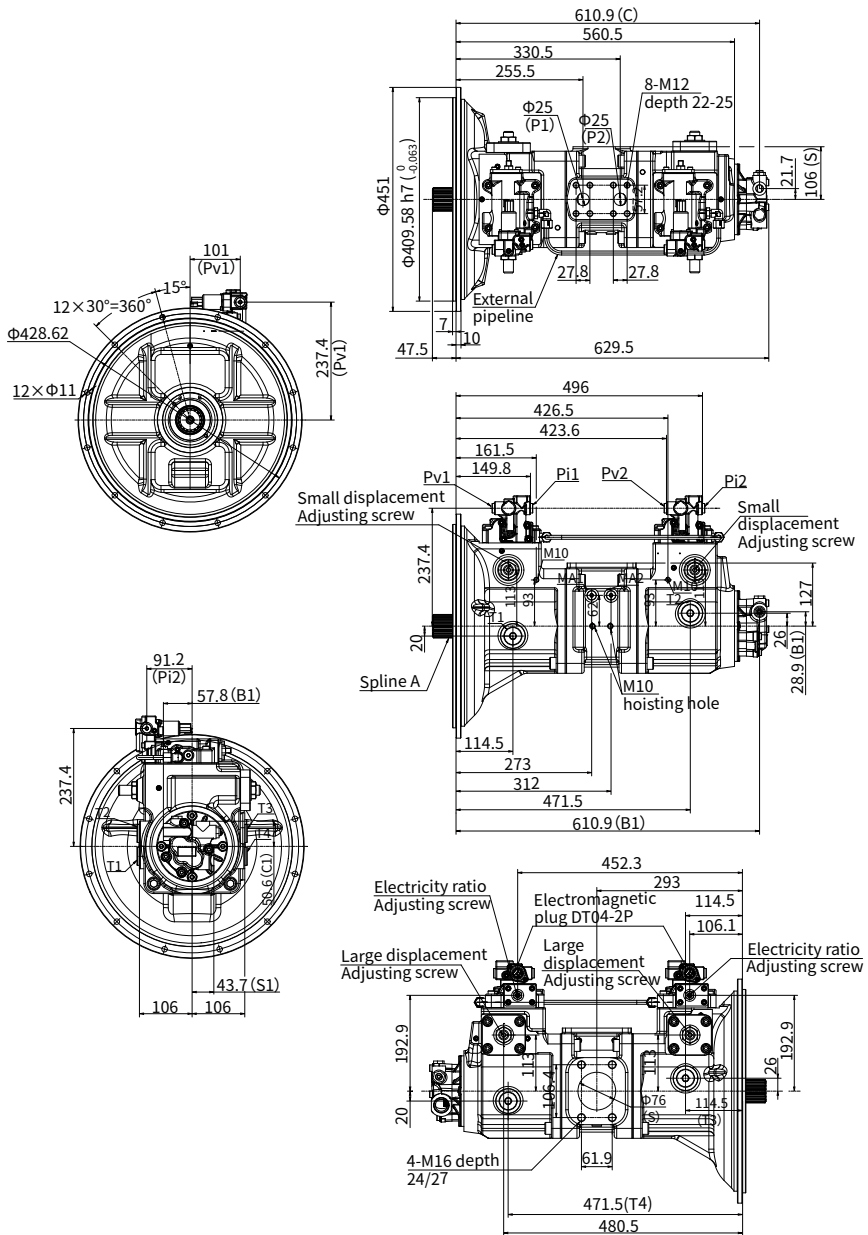

Installation size

·V93N 145 Description of oil port

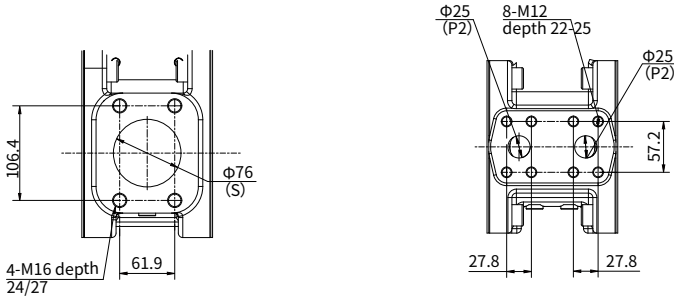

Port Details

	Port Name	Port Size and Description
P1,P2	Output Port	SAE 1" 4-M12×1.75, depth 22mm
S	Input Port	SAE 3" 4-M16×2, depth 24mm
T1,T2,T3,T4	Drain Port	G 3/4 depth 24mm
Pi1/Pi2	Pilot Port	G 1/4 depth 13mm
PV1/PV2	Pressure Measureing	G 1/4 depth 13mm
MA1,MA2,PCH	Pressure Measureing	G 1/4 depth 13mm
S1	Pilot Pump Output Port	G 3/4 depth 26mm
B1	Pilot Pump Input Port	G 1/2 depth 19mm
C	Pressure Measureing	G 1/4 depth 13mm

Installation size

·V93N 145 Flange

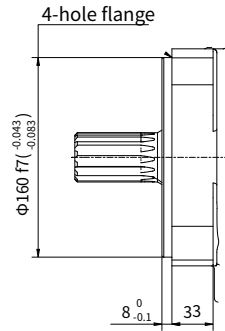
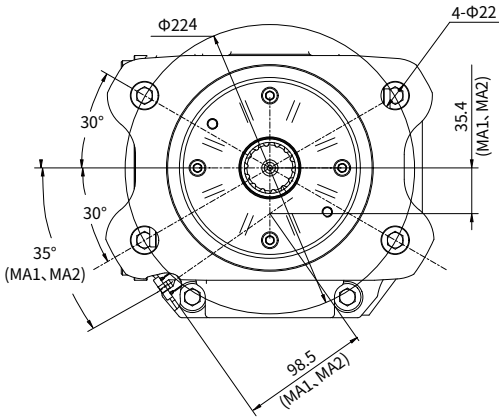

·V93N 145 Input shaft

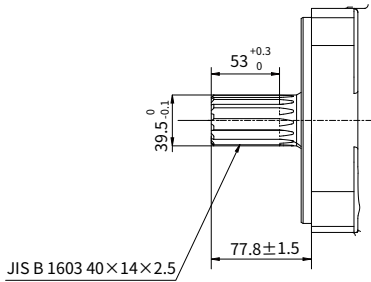

“J1” type spline shaft

V93N 375 Control principle

·F1 Electro-proportional displacement control principle

Electro-proportional displacement control: With pilot-pressure-related control, the pump displacement is adjusted in proportion to the pilot pressure. Basic position without pilot signal is $V_{g\ min}$, which includes the mechanically depressurized basic position $V_{g\ min}$. With increasing pilot pressure the pump swivels to a larger displacement. The necessary control power is taken from the operating pressure or the external control pressure applied to port P. If the pump is to be adjusted from the zero basic setting or from a low operating pressure, port P must be supplied with an external control pressure of at least 30 bar, maximum 50 bar.

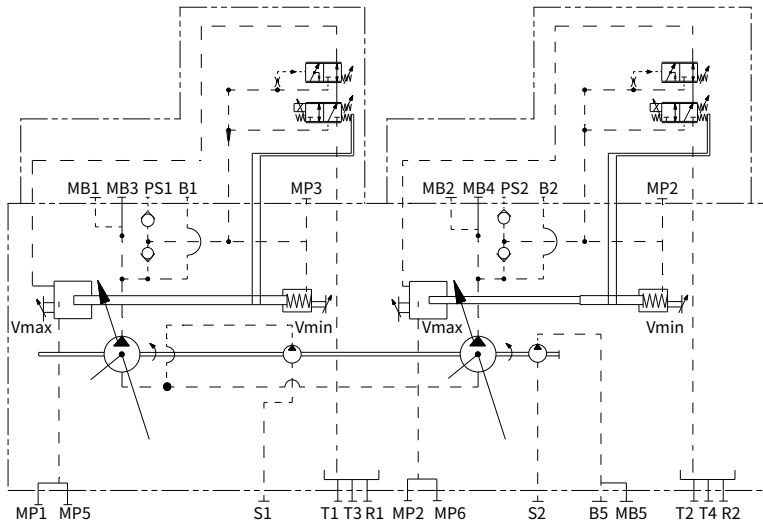

Note:

When ordering, please provide the information as below:

- Working pressure
- Maximum flow
- Minimum flow

Installation size

V93N 375 Type

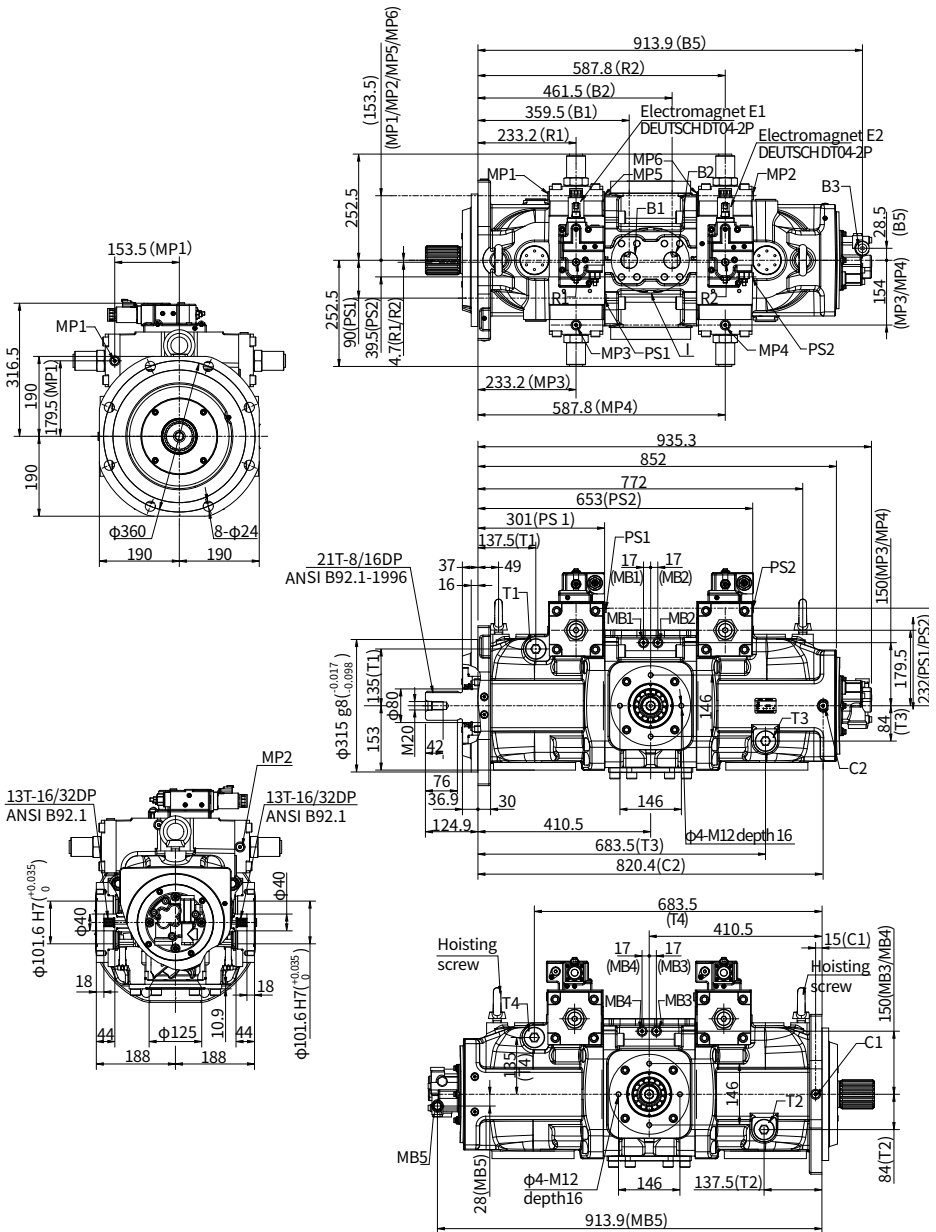

Installation size

·V93N 375 Description of oil port

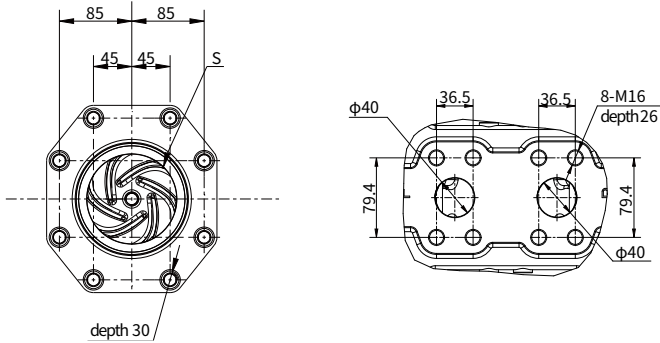

Port Details

	Port Name	Port Size and Description
P1,P2	Output Port	SAE 1" 4-M12×1.5, depth22mm
S	Input Port	SAE 2-1/2" 4-M12×1.75, depth18mm
T1,T2,T3,T4	Drain Port	G 3/4 depth20mm
Pi1/Pi2	Pilot Port	G 1/4 depth12mm
X1,X2	Pressure sensor port	G 1/4 depth12mm
MA1,MA3	Pressure Measuring	G 1/4 depth15mm
Pi	Pilot Pump Output Port	G 1/2 depth19mm
Si	Pilot Pump Input Port	G 3/4 depth20.5mm

Installation size

·V93N 375 Flange

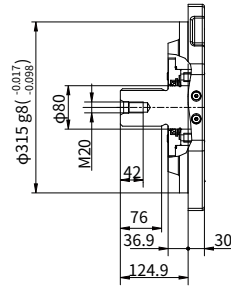
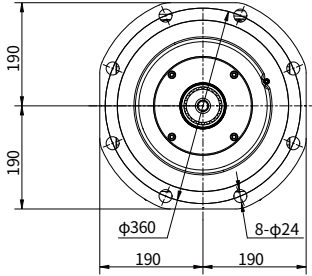

·V93N 375 Input shaft

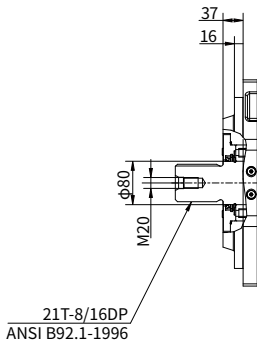

“X1” type spline shaft

China

+86 400 101 8889

America

+01 630 995 3674

Germany

+49 (30) 72088-0

Japan

+81 03 6809 1696



© This brochure can be reproduced, edited, reproduced or transmitted electronically without the authorization of Hengli Hydraulic Company. Due to the continuous development of the product, the information in this brochure is not specific to the specific conditions or applicability of the industry, thus, Hengli does not take any responsibility for any incomplete or inaccurate description.