



1.5.1

V90N-T SERIES

Swash-plate Type Axial Piston Variable Displacement Double Pump

V90N-T variable axial piston double pump is designed for the high pressure open circuit.

Displacement (cc/rev):	75×2	130×2	180×2	280×2	300×2
Nominal pressure (bar):	350	380	380	380	380
Max. pressure (bar):	400	420	420	420	420

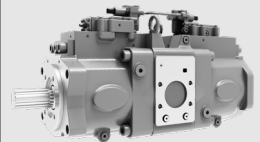

Contents

Technical Data	02
Type introduction	03-05
V90N 75T Type	
• Control principle	06-07
• Installation size	08-10
V90N 130T/180T Type	
• Control principle	11-12
• Installation size	13-17
V90N 280T Type	
• Control principle	18-19
• Installation size	20-21
V90N 300T Type	
• Control principle	12
• Installation size	23-24

Features

- Variable axial piston double pump design for the open circuit.
- Various controllers available: hydraulic and electrical control design available, which can combined the different controllers of flow control, pressure control and power control.
- High working pressure (400 bar) and long lifetime
- High efficiency, excellent self-priming performance
- Special pump housing structure design meets the low noise requirements.
- More suitable for mobile machinery like excavators, cranes, drilling rigs and so on.

Technical data

Size		V90N75T	V90N 130T	V90N 180T	V90N 280T	V90N 300T
Displacement(cc/rev)		75×2	130×2	180×2	280×2	300×2
Speed	Rated speed (rpm) ¹	2450	2200	2100	1800 (Self-Priming)	1800 (Self-Priming)
	Maximum speed (rpm) ²	3000	2500	2400	2100	2100
Pressure	Rated pressure (bar)	350	380	380	380	380
	Maximum pressure (bar)	400	420	420	420	420
Maximum torque (N.m) @Vgmax and Δp=380bar		415	786	1120	3120	3120
Case volume (L)		2.6	2.8	3.4	8	9
Suction port pressure (abs bar)		0.7 ~ 2				
Drain pressure (bar)		1				
Max. drain pressure (bar)		3				
Mass (Kg)		95	166	174	300	310
Temperature range (°C)		-20 ~ 95				
Hydraulic fluid viscosity range (mm ² /s)		10 ~ 1000* ³ (optimum viscosity range 16 ~ 36)				

- 1 Steady state suction pressure should be 0 bar and above (at normal condition);
- 2 If suction pressure less than 0 bar, Boost pressure should be required;
- 3 In case of 200-1000mm²/s, please allow system to warm up before using machine.

Type introduction

V90N	130	T	V	R	E1	/	A	J1	K0	N	G	M	S
①	②	③	④	⑤	⑥		⑦	⑧	⑨	⑩	⑪	⑫	⑬

Product series

①	Double pump, variable swash-plate design, open circuit	V90N
---	--	------

Displacement

②	Displacement cc/rev	75	130	180	280	300
---	---------------------	----	-----	-----	-----	-----

Structure type

③		75	130	180	280	300	Code	
	Structure type	Tandem double pump		●	●	●	●	●

Seals

④		75	130	180	280	300	Code
	FKM	●	●	●	●	●	V

Direction rotation

⑤		75	130	180	280	300	Code
	Clockwise	●	●	●	●	●	R
	Counter-clockwise			○	●	●	L

Control type

⑥		75	130	180	280	300	Code		
	Electric proportional displacement	Pilot operated proportional displacement control (positive control), 24V		●	●	●	●	●	E1
	Negative displacement control	Hydraulic pilot negative flow + Proportional increasing power control + (total power control)		●	●	●	●		H1
		Hydraulic pilot negative flow + Proportional decreasing power control + (total power control)		●	●	●	●		H2
Hydraulic pilot negative flow +divided power control		○	●	●	○		H3		

Type introduction

Mounting flange

	75	130	180	280	300	Code
⑦ SAE J617 N0.3 flywheel flange, see "Installation size" (Axial length : narrow)		●	●			A
SAE J617 N0.3 flywheel flange, see "Installation size" (Axial length : wide)		●				B
SAE J617 N0.2 flywheel flange			●			C
SAE C 127-2	●					C2
SAE J617 N0.1 flywheel flange			●			D
4-hole flange		●	○			E
				●	●	G4

Input shaft

	75	130	180	280	300	Code
⑧ SAE J744-32-4 14T 12/24DP	●					S3
SAE J744-44-4 13T 8/16		○				S5
JIS B 1603 40×14×2.5 (short)		●				J0
JIS B 1603 40×14×2.5		●				J1
JIS B 1603 47.5×17×2.5		●	●			J2
JIS B 1603 40×14×2.5 (long)		●				J3
JIS B 1603 47.5×17×2.5 (long)		●				J4
JIS B 1603 60×18×3				●	●	J6

Through drive and pilot pump

	75	130	180	280	300	Code
⑨ None	●	●	●	●	●	N
SAE A 82-2 SAE J744-16-4 9T 16/32DP		○	○			A1
SAE A 82-2 SAE J744-19-4 11T 16/32DP		○	○			A2
SAE B 101-2 SAE J744-22-4 13T 16/32DP		○	○			B1
SAE B 101-2 SAE J744-25-4 15T 16/32DP		○	○			B2
With pilot gear pump and pressure relief valve (only for none through drive)	●	●	●	●	●	K0

Type introduction

PTO Power port drive

	75	130	180	280	300	Code	
⑩	No pressurization, no force extractor	●	●	●	●	N	
	Pressurization, no force extractor				●	H	
	SAE A 82-2 SAE J744-16-4 9T 16/32DP	●			○	○	A1
	SAE A 82-2 SAE JJ744-22-4- 13T 16/32DP		●	●			A3
	SAE B 101-2 SAE J744-22-4 13T 16/32DP		●	●	●	●	B1
	SAE B 101-2 SAE J744-25-4 15T 16/32DP		●	●	●	●	B2
	SAE C 127-2 SAE J744-32-4 14T 12/24DP				●	●	C1

Connection type (except inlet and outlet port)

	75	130	180	280	300	Code
⑪	UNC port, ISO11926	○	○	○		A
	Metric port, ISO 6149	○	○	○		M
	BSPP G thread, JIS B2351	●	●	●	●	●

Thread type of Flange Port

	75	130	180	280	300	Code
⑫	UNC threads (only for UNC port)	○	○	○		A
	Metric thread	●	●	●	●	●

Standard / special version

	75	130	180	280	300	Code
⑬	Standard version	●	●	●	●	None
	Special version	○	○	○	○	S

Remark: ● = Available; ○ = On request

V90N 75T Control principle

· E1 Electro-proportional displacement control principle

Electro-proportional displacement control: With pilot-pressure-related control, the pump displacement is adjusted in proportion to the pilot pressure. Basic position without pilot signal is $V_g \text{ min}$, which includes the mechanically depressurized basic position $V_{g \text{ min}}$. With increasing pilot pressure the pump swivels to a larger displacement. The necessary control power is taken from the operating pressure or the external control pressure applied to port P. If the pump is to be adjusted from the zero basic setting or from a low operating pressure, port P must be supplied with an external control pressure of at least 30 bar, maximum 50 bar.

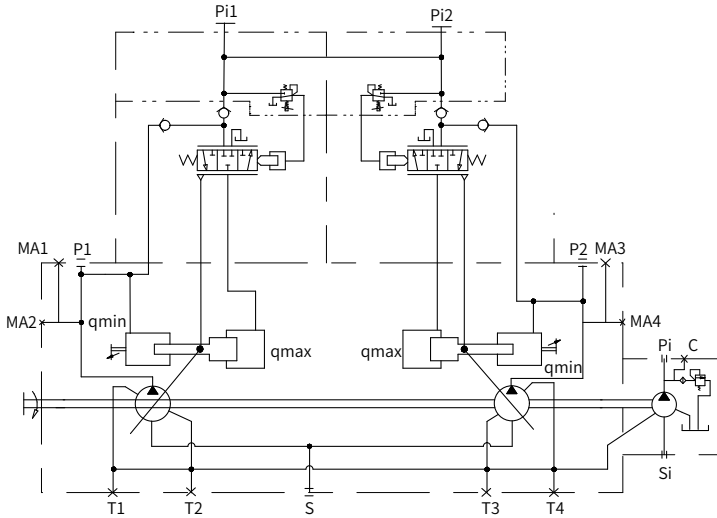

Note:
When ordering, please provide the information as below:
· Working pressure
· Maximum flow
· Minimum flow

· H1 Negative flow control schematic

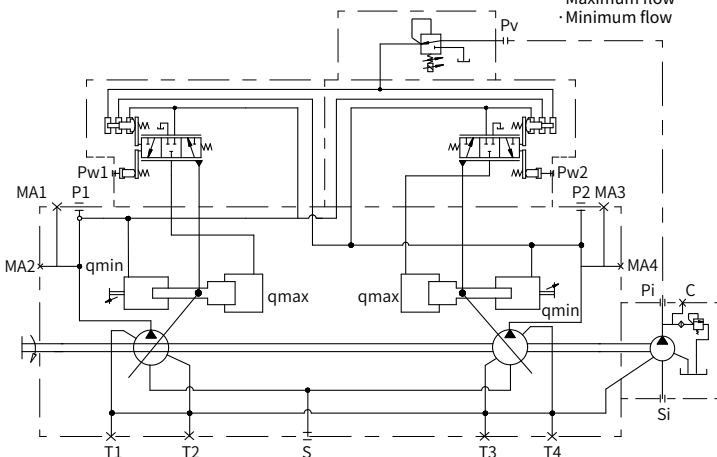

V90N 75T Control principle

-H2 Negative flow control schematic

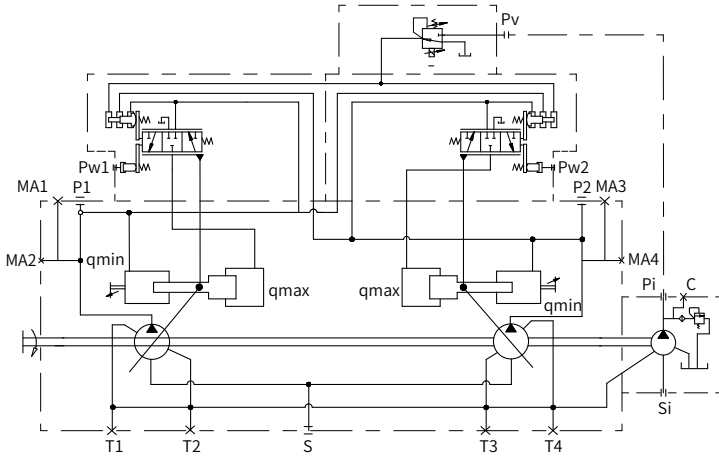

Note:

When ordering, please provide the information as below:

- Working pressure
- Maximum flow
- Minimum flow

-H3 Negative flow control schematic

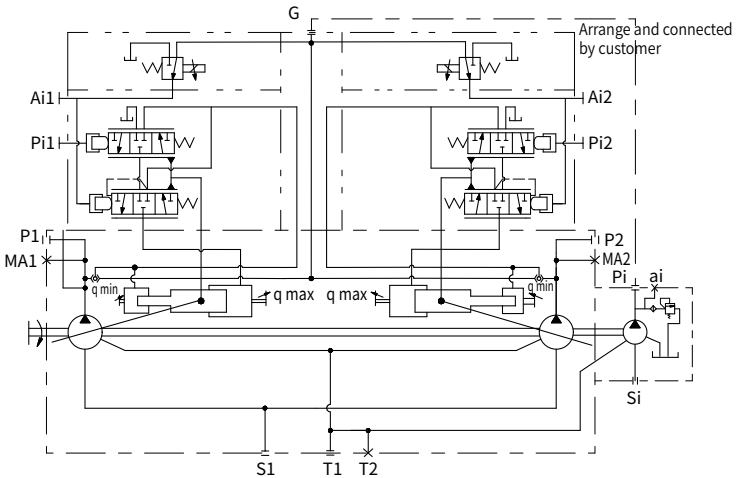

Installation size

V90N 75T Type

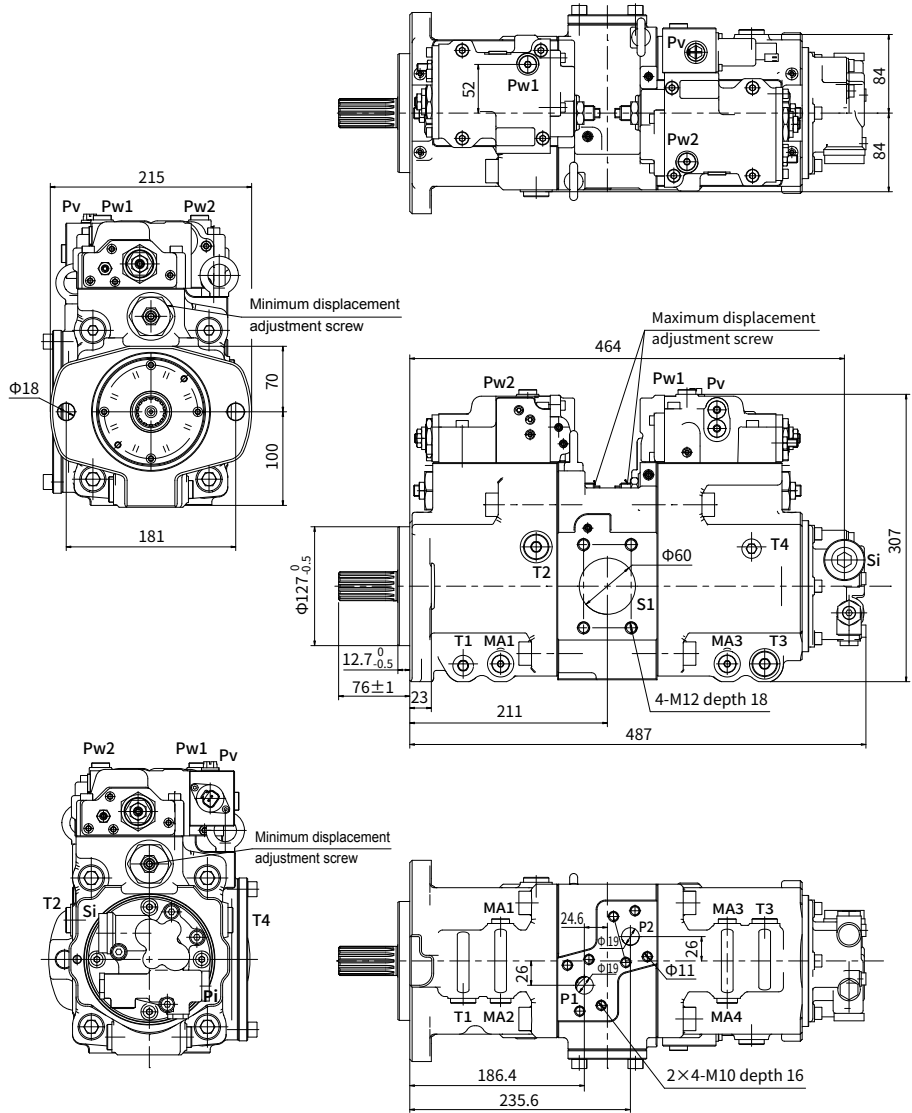

Installation size

·V90N 75T Description of oil port

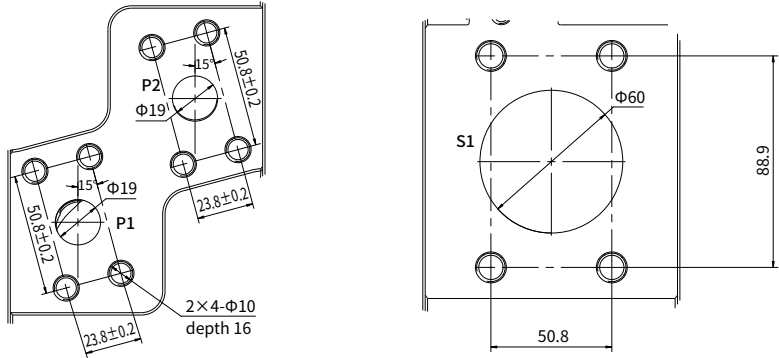

Port Details

	Port Name	Port Size and Description
P1,P2	Output Port	SAE 3/4" 4-M10×1.5, depth 17mm
S1	Input Port	SAE 2-1/2" 4-M12×1.75, depth 20mm
T1,T2,T3,T4	Drain Port	G 1/2 depth 19mm
Pw1/Pw2	Pilot Port	G 1/4 depth 12mm
MA1,MA3	Pressure Measureing	G 1/4 depth 15mm
MA2,MA4	Pressure Sensor Port	G 3/8 depth 16mm
Pi	Pilot Pump Output Port	G 1/2 depth 19mm
Si	Pilot Pump Input Port	G 3/4 depth 20.5mm
Pv	External Control Pressure Port	G 1/4 depth 12mm

Installation size

·V90N 75T Flange

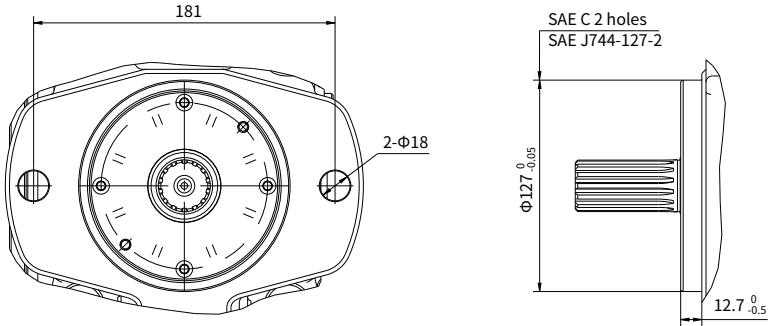

·V90N 75T Input shaft

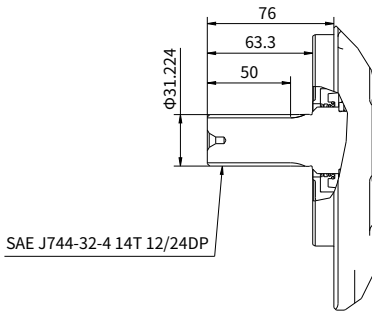

“S3” type spline shaft

V90N 130T/180T Control principle

·E1 Electro-proportional displacement control principle

Electro-proportional displacement control: With pilot-pressure-related control, the pump displacement is adjusted in proportion to the pilot pressure. Basic position without pilot signal is $V_{g \min}$, which includes the mechanically depressurized basic position $V_{g \min}$. With increasing pilot pressure the pump swivels to a larger displacement. The necessary control power is taken from the operating pressure or the external control pressure applied to port P. If the pump is to be adjusted from the zero basic setting or from a low operating pressure, port P must be supplied with an external control pressure of at least 30 bar, maximum 50 bar.

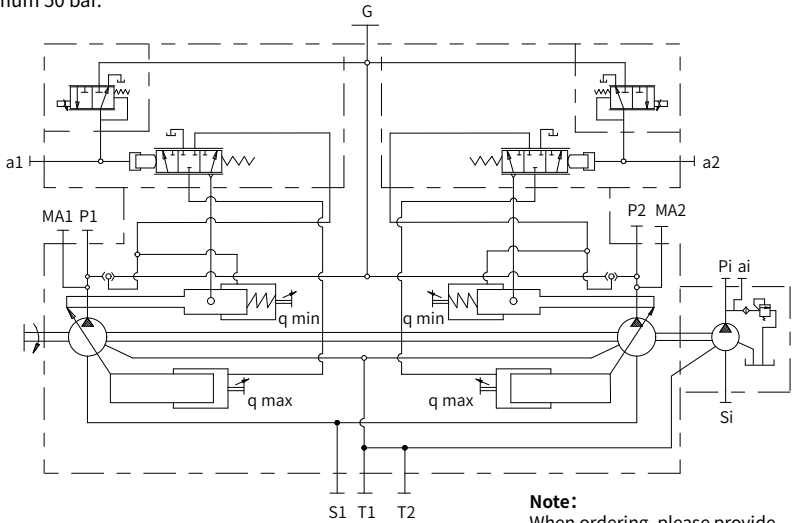

Note:
When ordering, please provide the information as below:
· Working pressure
· Maximum flow
· Minimum flow

·H1 Negative flow control schematic

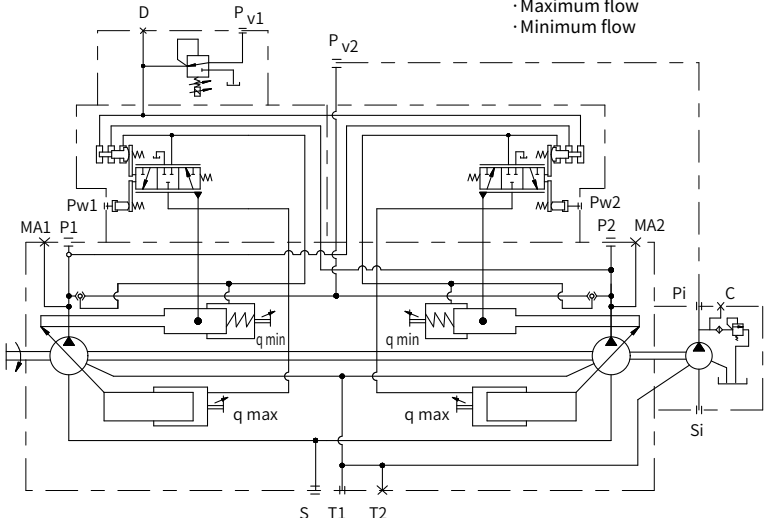

V90N 130T/180T Control principle

· H2 Negative flow control schematic

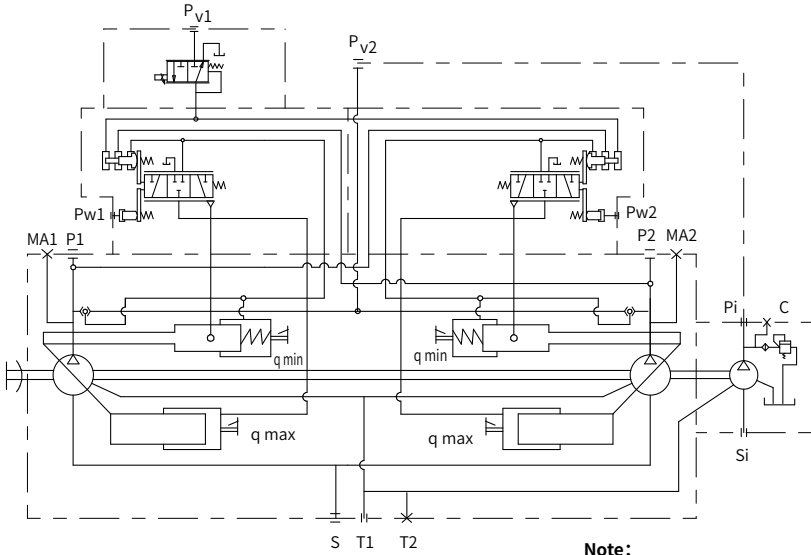

Note:

When ordering, please provide the information as below:

- Working pressure
- Maximum flow
- Minimum flow

· H3 Negative flow control schematic

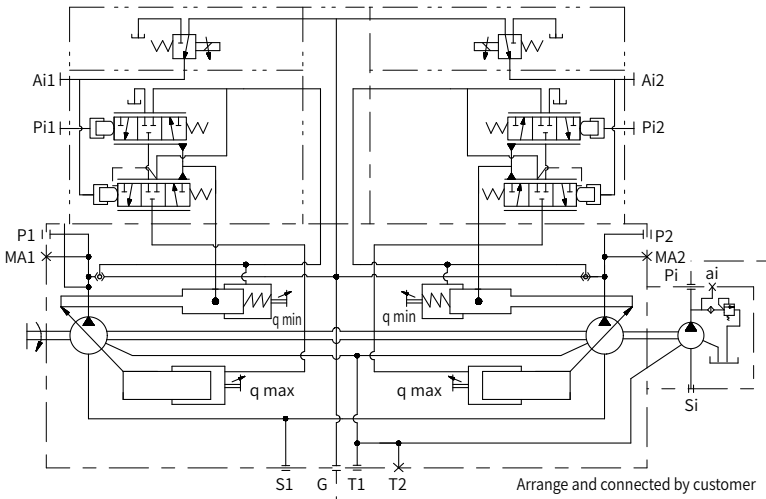

Installation size

•V90N 130T Type

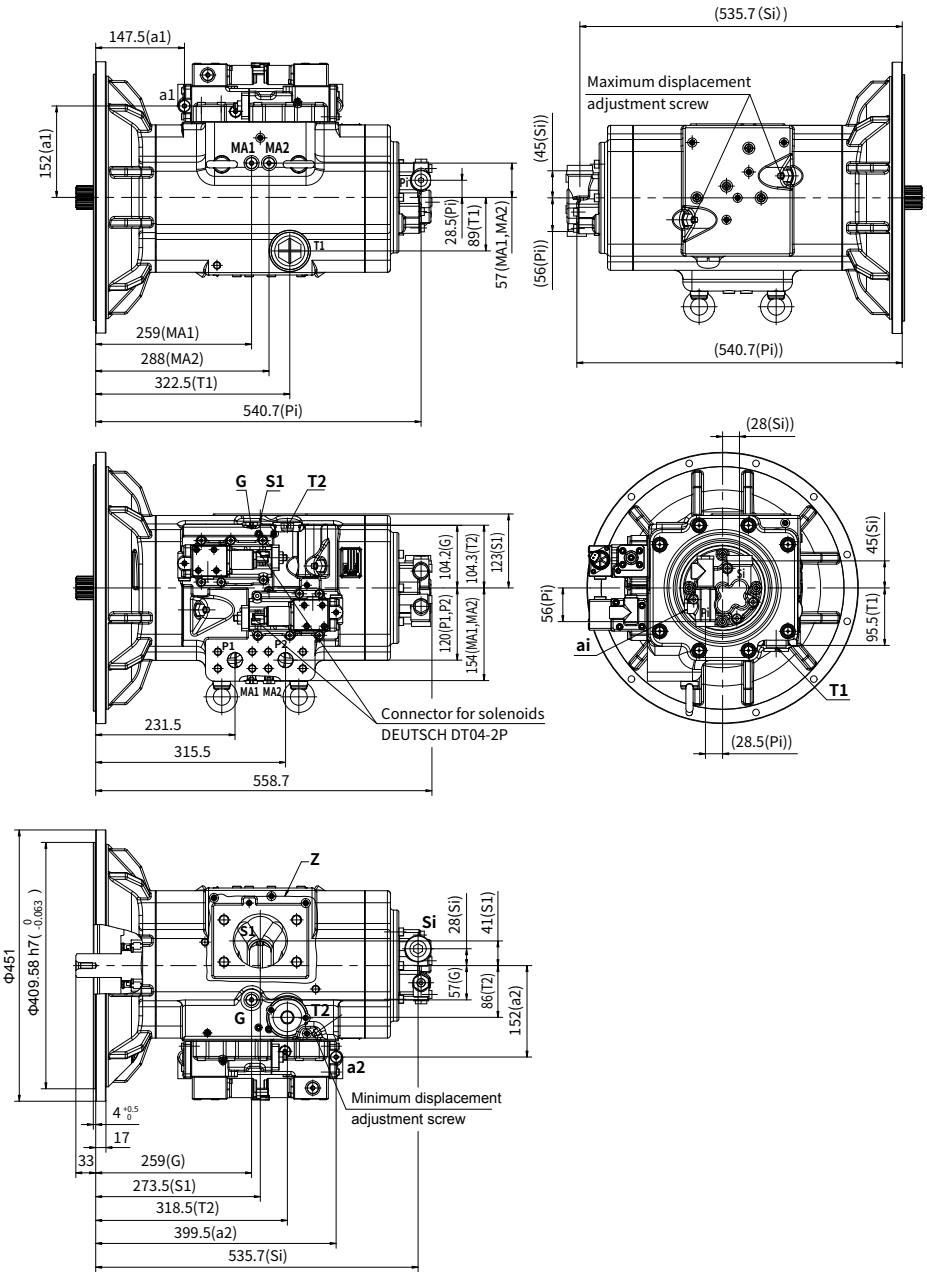

Installation size

·V90N 180T type

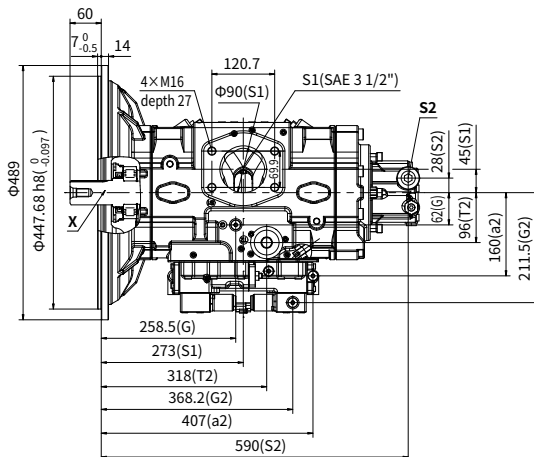
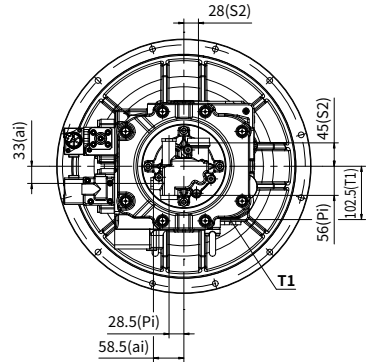
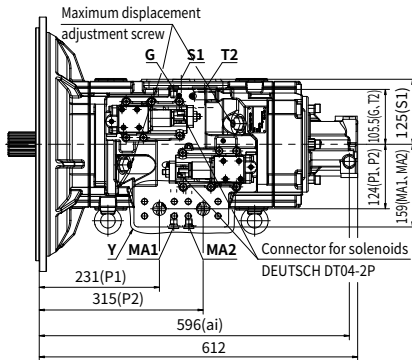
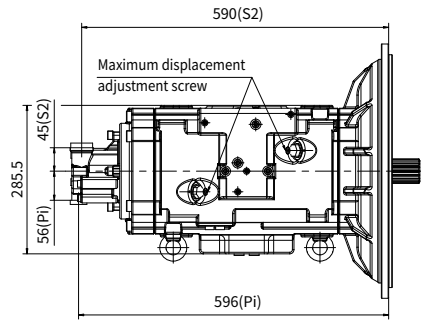
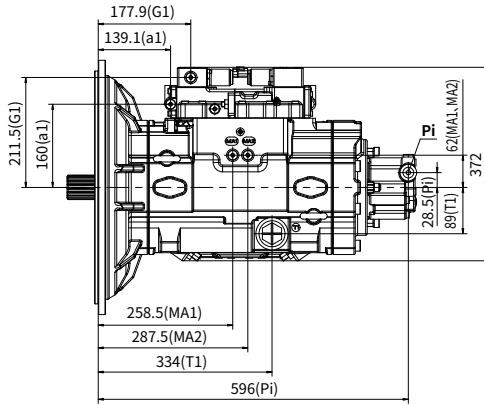

V90N 130T/180T Installation size

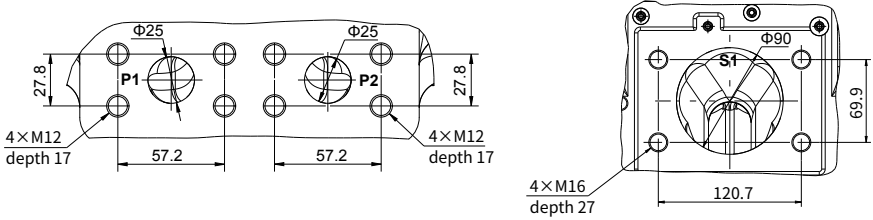

Port Details

	Port Name	Port Size and Description
P1、 P2	Output Port	1" SAE J518C Code 62 (6000psi)
		4×M12 depth 17mm
S1	Input Port	3-1/2" SAE J518C Code 61 (500psi)
		4×M16 depth 27mm
T1、 T2	Drain Port	G1 1/4 , G 3/4
G	External Control Pressure Port	G 1/4
MA1, MA2	Pressure Measureing	G 1/4
Pi	Output Port	G 1/2
Si	Input Port	G 3/4

V90N 130T/180T Installation size

• Flywheel flange

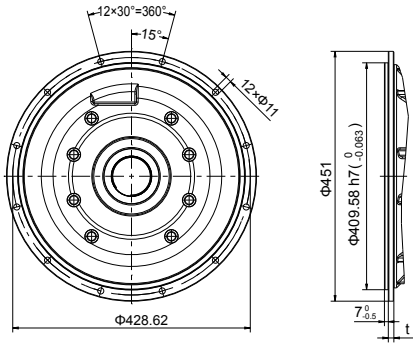

A Type Note: V90N130T t=10
V90N180T t=14

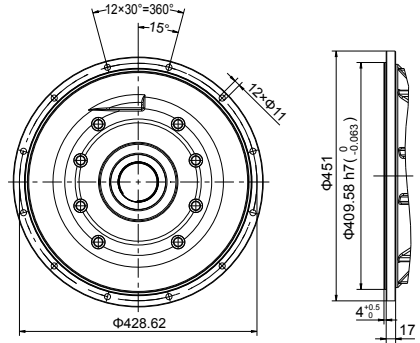

B Type

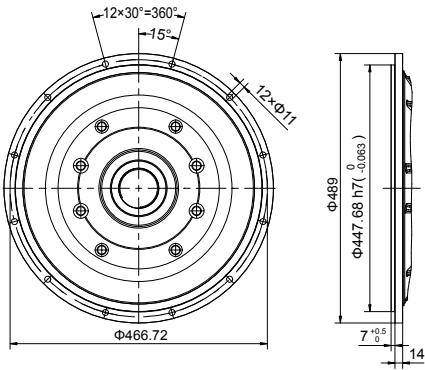

C Type

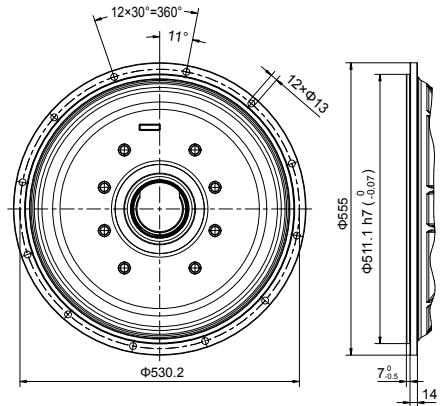

D Type

V90N 130T/180T Installation size

• Input shaft

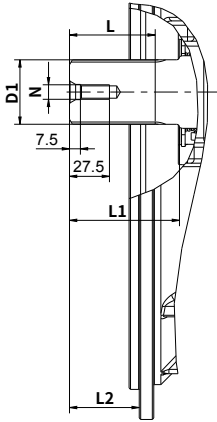

Size		D1	L	L1	N	L2			
						A	B	C	D
130	S5	44.45	58	74.9	M10	48	33	—	—
	J1	39.5							
	J2	47							
	J0	39.5	53	68.9		42	27	—	—
	J3	39.5	68	88.9		62	47	—	—
	J4	47	68	94.9		64	45	—	—
180	J2	47	63	81.8	M16	—	—	60	63
		47	48	66.8		43	—	58	—

01

V90N 280T Control principle

· E1 Electro-proportional displacement control principle

Electro-proportional displacement control: With pilot-pressure-related control, the pump displacement is adjusted in proportion to the pilot pressure. Basic position without pilot signal is $V_g \text{ min}$, which includes the mechanically depressurized basic position $V_{g \text{ min}}$. With increasing pilot pressure the pump swivels to a larger displacement. The necessary control power is taken from the operating pressure or the external control pressure applied to port P. If the pump is to be adjusted from the zero basic setting or from a low operating pressure, port P must be supplied with an external control pressure of at least 30 bar, maximum 50 bar.

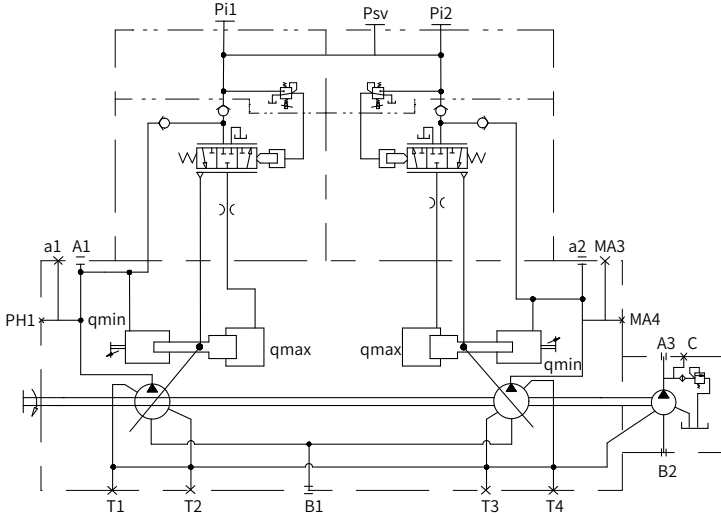

· H1 Negative flow control schematic

Note:

When ordering, please provide the information as below:

- Working pressure
- Maximum flow
- Minimum flow

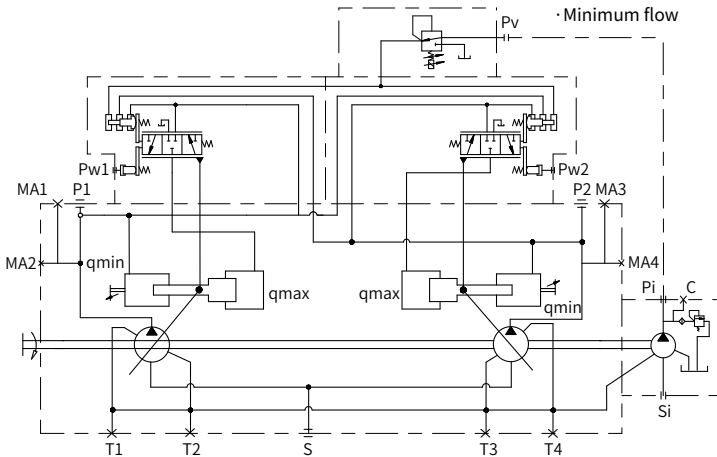

V90N 280T Control principle

·H2 Negative flow control schematic

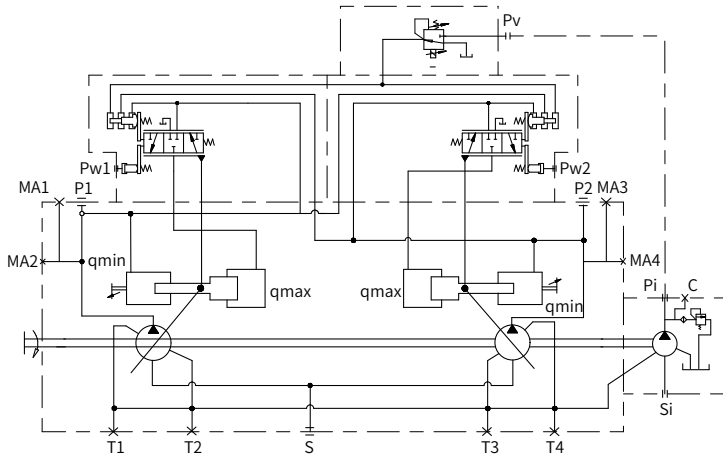

Note:

When ordering, please provide the information as below:

- Working pressure
- Maximum flow
- Minimum flow

Installation size

V90N 280T Type

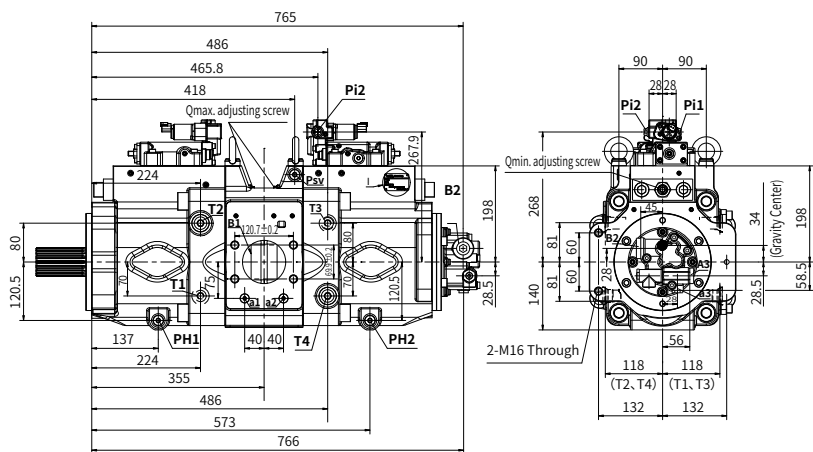
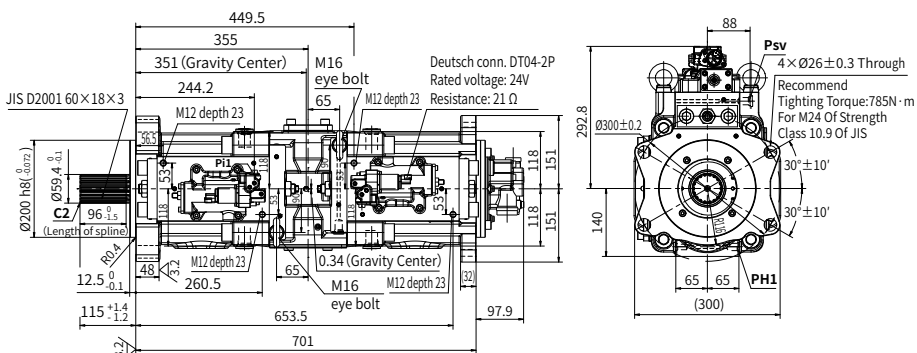

Installation size

·V90N 280T Description of oil port

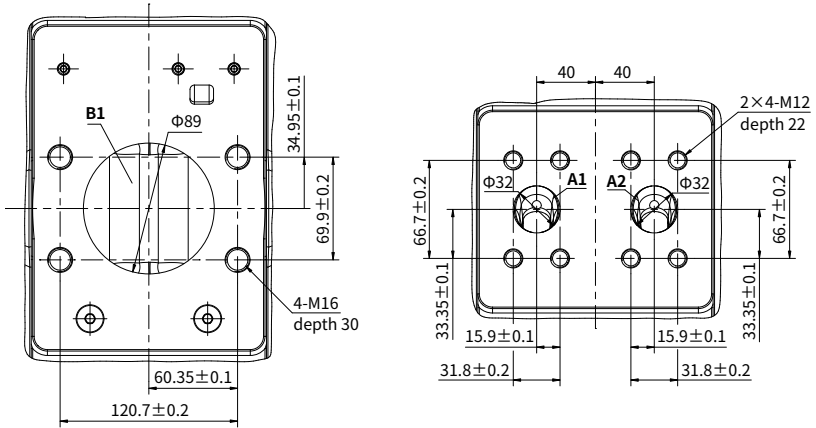

Port Details

	Port Name	Port Size and Description	Tightening Torque(N.m)
A1, A2	Output Port	SAE 6000psi 1 1/4"	98
B1	Suction Port	SAE 2500psi 3 1/2	240
T1, T2, T3, T4	Drain Port	G 3/4 depth 20mm	170
Psv	Serve Assist Port	G 3/8 depth 17mm	74
Pi1, Pi2	Pilot Port	G 1/4 depth 12mm	36
a1, a2	Gauge Port	G 1/4 depth 15mm	36
PH1, PH2	Gauge Port	G 3/8 depth 15mm	74
A3	Gear Pump Output Port	G 1/2 depth 19mm	53
B2	Gear Pump Suction Port	G 3/4 depth 20.5mm	74

V90N 300T Control principle

· E1 Electro-proportional displacement control principle

Electro-proportional displacement control: With pilot-pressure-related control, the pump displacement is adjusted in proportion to the pilot pressure. Basic position without pilot signal is $V_g \text{ min}$, which includes the mechanically depressurized basic position $V_{g,\text{min}}$. With increasing pilot pressure the pump swivels to a larger displacement. The necessary control power is taken from the operating pressure or the external control pressure applied to port P. If the pump is to be adjusted from the zero basic setting or from a low operating pressure, port P must be supplied with an external control pressure of at least 30 bar, maximum 50 bar.

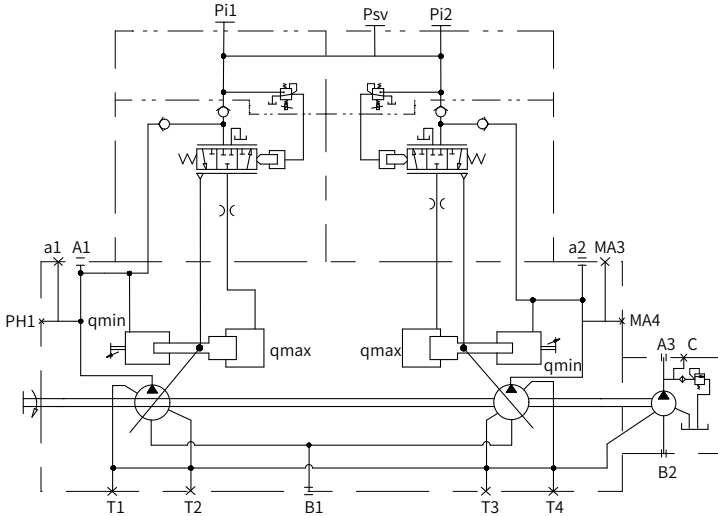

Note:

When ordering, please provide the information as below:

- Working pressure
- Maximum flow
- Minimum flow

Installation size

V90N 300T Type

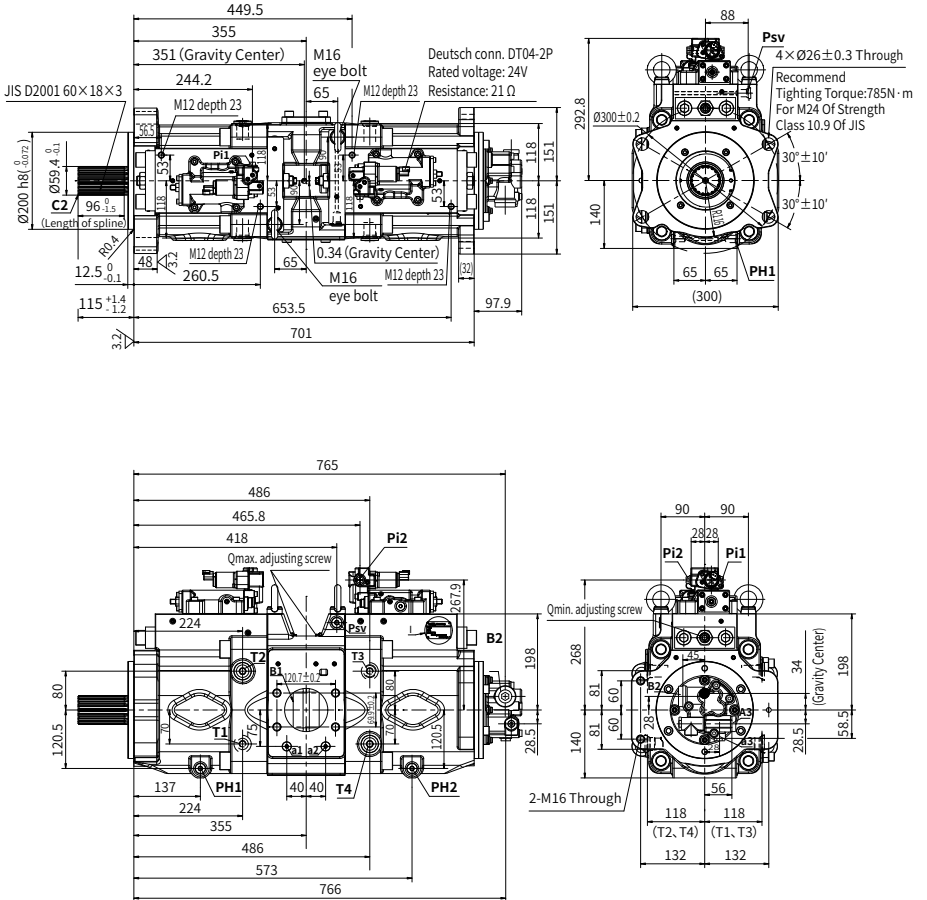

01

Installation size

·V90N 300T Description of oil port

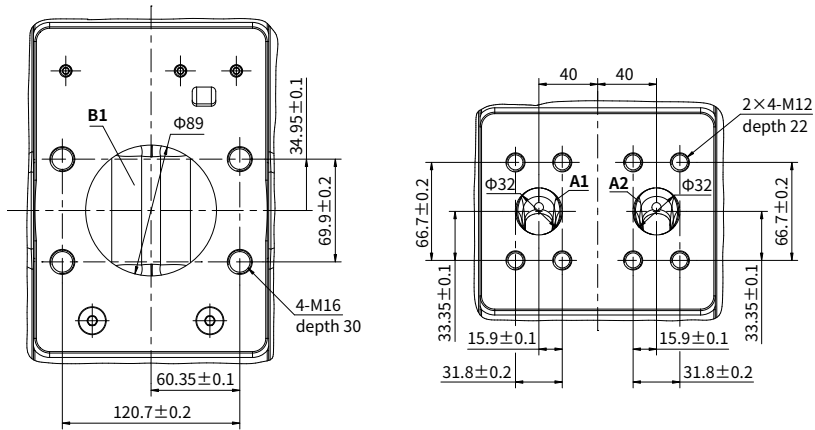

Port Details

	Port Name	Port Size and Description	Tightening Torque(N.m)	
	A1, A2	Output Port	SAE 6000psi 1 1/4"	98
	B1	Suction Port	SAE 2500psi 3 1/2	240
	T1, T2, T3, T4	Drain Port	G 3/4 depth 20mm	170
	Psv2	Serve Assist Port	G 3/8 depth 17mm	74
	Psv1	Serve Assist Port	G 1/4 depth 15mm	36
	Pi1, Pi2	Pilot Port	G 1/4 depth 13mm	16
	a1, a2 PH3, PH4	Gauge Port	G 1/4 depth 15mm	36
	a3,a4	Gauge Port	G 1/4 depth 13mm	16
	PB	Gauge Port	G 1/8 depth 12mm	12
	PH1,PH2	Gauge Port	G 3/8 depth 17mm	74

China

+86 400 101 8889

America

+01 630 995 3674

Germany

+49 (30) 72088-0

Japan

+81 03 6809 1696



© This brochure can be reproduced, edited, reproduced or transmitted electronically without the authorization of Hengli Hydraulic Company. Due to the continuous development of the product, the information in this brochure is not specific to the specific conditions or applicability of the industry, thus, Hengli does not take any responsibility for any incomplete or inaccurate description.