

In/line

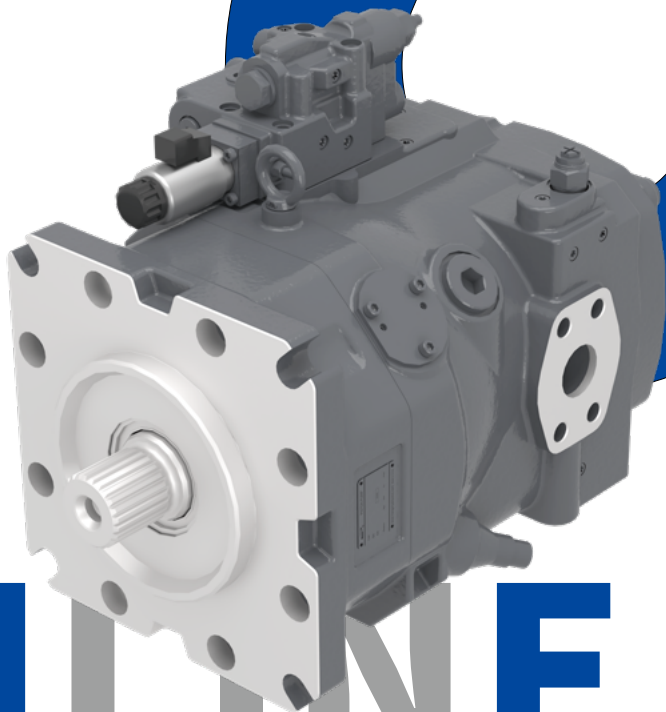

IN/LINE.

V32G series

Robust High-pressure Piston Pump

Open circuit

Nominal pressure p_{nom} : 350~420 bar

Peak pressure p_{max} : 420~450 bar

Geometric displacement V_{max} : 145~300 cm³/rev



2024-09



Hengli InLine Hydraulik GmbH is located in Berlin, Germany. In 2015, Hengli Hydraulics wholly-owned the InLine hydraulic factory, dedicated to providing customers with high-performance heavy-duty piston pumps for various applications.

The company has 70 years of experience in the design and manufacture of axial piston pumps. The products are known for sturdy construction, heavy load capability and high reliability. With wide range of controllers, the InLine products can meet the needs of various applications and are now widely used in mechanical equipment such as mobile cranes, rotary drills, shield machines, concrete pump, dredgers, and industrial hydraulic systems such as forging presses and extrude presses.

Kaemper & Demag

In the 1950s, Kämper began working with the German company DEMAG to manufacture hydraulic products, pumps and valves.

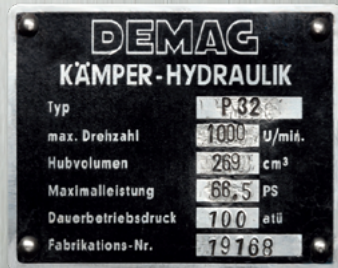

Bellows Valvair

In the 1960s, The American company Bellows Valvair extended its production to focus on successful and innovative axial piston pumps.



VOLVO

In 1973, VOLVO took over the company and with the V30B and V30D set new standards for reliability and service life.

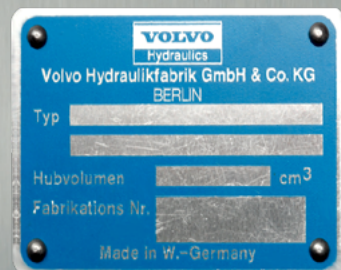



VOAC

In the context of the merger between VOLVO and Atlas Copco, the Berlin company also began supplying its products under the new label VOAC.

HAWE

In 1999, HAWE Hydraulik from Munich takes over the company and immediately begins to expand the product range, including the typical V60N and V30E pumps for mobile applications.

HAWE InLine & Hengli

In 2015, HAWE and Hengli establish worldwide cooperation, under which Hengli takes over management of production in Berlin.

InLine Changzhou

In 2016, Changzhou InLine established a subsidiary in Changzhou, China, focusing on after-sales and application consultant service for customers from Chinese market.

Contents

1	Overview: variable displacement axial piston pump types V32G	05
2	Available versions, main data	06
2.1	Basic version	07
2.2	Controller switching symbols	09
3	Parameters	10
3.1	General	10
3.2	Planning information for parameters	12
3.3	Swash angle pick-up	12
3.4	Section view	13
3.5	Controller characteristic curves	14
4	Dimensions	16
4.1	Type V32G 145/160	16
4.2	Type V32G 200	19
4.3	Type V32G 300	22
4.4	Through drive	25
5	Installation information	29
5.1	General information	29
5.2	Installation positions	30
5.3	Tank installation	31
6	Installation, operation and maintenance information	32
6.1	Designated use	32
6.2	Assembly information	32

1 Overview: variable displacement axial piston pump types V32G

InLine Hydraulik GmbH has 70 years for heavy-load piston pump in R&D and manufacturing, and based on rich experience in market application, it has developed a new generation of V32G series products, which can help machinery and equipment cope with various harsh conditions.

The V32G series pump has a high working pressure, the nominal pressure can reach 420 bar, and the peak pressure can reach 450 bar. The overall structure adopts a 45 ° oblique design to achieve compact and lightweight purposes. The V32G series pump has higher power density, which is about 5% higher than the previous generation.

The pumps also have a low outlet standby pressure, which greatly reduces power loss. Moreover, while improving the self-priming performance, the optional built-in booster impeller makes the V32G series pump have a higher speed. In addition, the use of enhanced heavy-duty bearings and spindle design, through the shaft drive, it can adapt to multi-pump series and other large torque and high speed conditions, and has a longer service life.

Adapt to the development of digitalization, V32G series pumps can be combined with angular displacement and pressure sensors to achieve closed-loop control and digital adjustment of flow, pressure and power, effectively reduce hysteresis, higher control accuracy, and with intelligent control and working condition data analysis and processing, to achieve life cycle monitoring.

In addition, thanks to the low noise housing and optimized valve plate structure, the V32G series pumps meet the low noise requirements of the hydraulic components of the whole machine.

Features and benefits:

- High continuous pressure
- Excellent self-priming performance, the minimum self-priming pressure is 0bar (relative pressure)
- Lower oil outlet standby pressure to reduce power loss(10bar)
- Enhanced bearing to improve service life
- Compact design to achieve a breakthrough in higher power density ratio
- Effectively reduce the amount of hysteresis, high control accuracy
- Low noise

Intended applications:

- Mobile cranes
- Drilling rigs
- Tunnel boring machine
- Concrete pump
- Dredgers
- Forging presses
- Extrude presses



V32G 200

Variable displacement
axial piston pump

2 Available versions, main data

2.1 Basic version

Circuit symbol:



Order coding example:

V32G	L	200	R	D1	F	V	2	/LRDRE1	-A1	-XX
------	---	-----	---	----	---	---	---	---------	-----	-----

Internal coding

Flange version

Table 8: Flange version
(output side)

Controller

Table 7: Controller

Additional function

Table 6: Additional functions

Seal

Table 5: Seals

Flange version

Table 4: Flange version (input side)

Shaft version

Table 3: Shaft version

Rotating direction

Table 2: Rotating direction

Nominal size

Table 1: Nominal size

With charge pump

(No code without booster pump)

Basic type

2.1 Basic version

Table 1: Nominal size

Coding	Geometric displacement (cm ³ /rev.)	Nominal pressure P _{nom} (bar)	Peak pressure P _{max} (bar)
145	145	420	450
160	160	420	450
200	203	420	450
300	300	350	420

Table 2: Rotating direction

Coding	Description	Specifications			
		145	160	200	300
L	Anti-clockwise *	○	○	○	○
R	Clockwise *	●	●	●	●

i Note: "*" mean is facing the drive shaft. ● = Available ○ = Under development

Table 3: Shaft version

Coding		Designation/Standard	Product model	Max. drive torque (Nm)
"D" type spline shaft	D1	W50×2×24×9g DIN5480	V32G 145, V32G 160, V32G 200	3140
	D2	W60×2×28×9g DIN5480	V32G 300	5780
"S" type spline shaft	S6 *	SAE J744 13T 8/16DP	V32G 145, V32G 160, V32G 200	1640
	S7 *	SAE J744 15T 8/16DP	V32G 145, V32G 160, V32G 200	2670
"K" type straight shaft	K2	Φ50 A 14×9×80 DIN6885	V32G 145, V32G 160	1450
	K3	Φ55 A 16×10×100 DIN6885	V32G 200	2200
	K4	Φ60 A 18×11×100 DIN6885	V32G 300	2750

i Note: "*" mean is unconventional options.

Table 4: Flange version (input side)

Coding	Description	Designation	Product model
F	Flange	SAE J744 152-4	V32G 145, V32G 160
		SAE J744 165-4	V32G 200, V32G 300

2.1 Basic version

Table 5: Seal

Coding	Description
V	FKM, permissible temperature range -25°C ~ 115°C (standard)
N	NBR, including the shaft seal is completely made of nitrile rubber, permissible temperature range -40°C ~ 90°C (optional)

Table 6: Additional functions, pivoting angle indicator

Coding	Description
0	None
1	With indicator
2	With angle pick-up (Hall sensor)

Table 7: Controller

Control type	Code	Specifications			
		145	160	200	300
Fixed setting, Electric proportional displacement, Pressure Cut-off	LRDRE1	●	●	●	●
Fixed setting, Pressure Cut-off, Load sensing	LRDS	●	●	●	●
Electric proportional override, Load sensing	LISO	●	●	●	●
Fixed setting, Pressure Cut-off, Remote pressure	LRDG	●	●	●	●
Electric proportional displacement, Pressure Cut-off	DRE1	●	●	●	●
Fixed setting, Electric proportional displacement, Remote pressure	LRDGE1	●	●	●	●

 Note: ● = Available ○ = Under development

Table 8: Flange version (output side)

Structure type	Flange	Shaft
0	Without through drive	
A1	SAE-A 2-hole J744 82-2 ISO 3019-1	SAE A J744 (16-4 ISO 3019-1) 9T 16/32 DP
A2	SAE-A 2-hole J744 82-2 ISO 3019-1	SAE A-B J744 (19-4 ISO 3019-1) 11T 16/32 DP
B1	SAE-B 2-hole J744 101-2 ISO 3019-1	SAE B J744 (22-4 ISO 3019-1) 13T 16/32 DP
	SAE-B 4-hole J744 101-4 ISO 3019-1	SAE B J744 (22-4 ISO 3019-1) 13T 16/32 DP
B2	SAE-B 2-hole J744 101-2/4 ISO 3019-1	SAE B-B J744 (25-4 ISO 3019-1) 15T 16/32 DP
C1	SAE-C 2-hole J744 127-2 ISO 3019-1	SAE C J744 (32-4 ISO 3019-1) 14T 12/24 DP
C2	SAE-C 4-hole J744 127-4 ISO 3019-1	SAE C J744 (32-4 ISO 3019-1) 14T 12/24 DP
D1	SAE-D 4-hole J744 152-4 ISO 3019-1	SAE D&E J744 (44-4 ISO 3019-1) 13T 8/16 DP
D2	SAE-D 4-hole J744 152-4 ISO 3019-1	N45×2×21×9H DIN 5480
D3	SAE-D 4-hole J744 152-4 ISO 3019-1	N50×2×24×9H DIN 5480
E1	SAE-E 4-hole J744 165-4 ISO 3019-1	SAE F J744 (50-4 ISO 3019-1) 15T 8/16 DP
E2	SAE-E 4-hole J744 165-4 ISO 3019-1	N50×2×24×9H DIN 5480
E3	SAE-E 4-hole J744 165-4 ISO 3019-1	N60×2×28×9H DIN 5480

2.2 Controller switching symbols

LRDRE1

Fixed setting, Electric proportional displacement, Pressure Cut-off

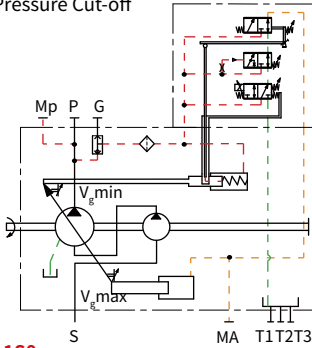

L1S0

Electric proportional override, Load sensing

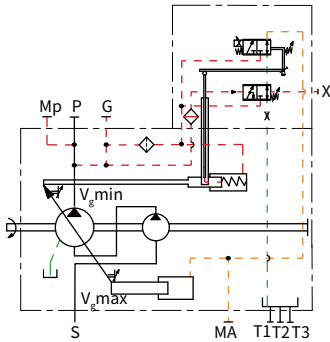

DRE1

Electric proportional displacement, Pressure Cut-off

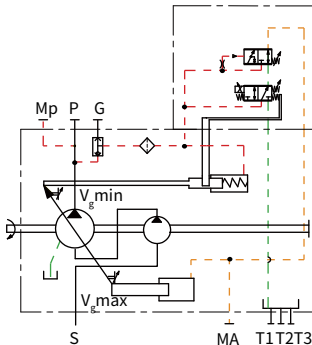

LRDS

Fixed setting, Pressure Cut-off, Load sensing

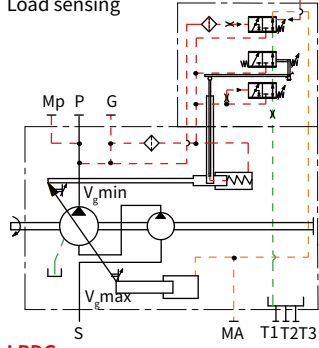

LRDG

Fixed setting, Pressure Cut-off, Remote pressure

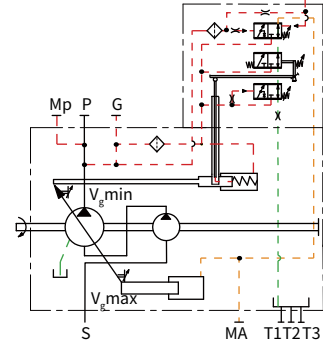

LRDGE1

Fixed setting, Electric proportional displacement, Remote pressure

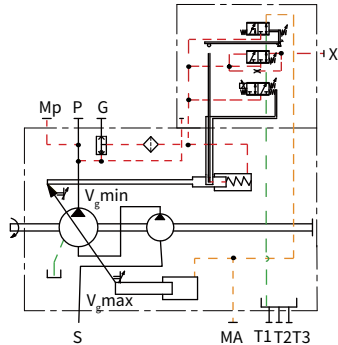

3 Parameters

3.1 General

Designation	Variable displacement axial piston pump
Design	The swash plate principle
Mounting	Flange mounting or foot bracket
Surface	Temporarily protected
Drive/output torque	See Chapter 3, "Parameters" , under "Additional parameters"(P11 page)
Installation positions	Any (for installation information see Chapter 5, "Installation information")
Rotating direction	Clockwise or anti-clockwise
Ports	· Suction port · Pressure port · Drain port · Pressure gauge connection
Optimal hydraulic oil working require	Hydraulic oil: according to DIN 51524 Part 1 to 3; ISO VG 10 to 68 according to DIN 51519 Continuous operation viscosity range: min. approx. 10; max. approx. 400 mm ² /s Optimal working viscosity range: 16 to 36mm ² /s, when lower than 16mm ² , please contact InLine Hydraulik GmbH. Also suitable for biologically degradable pressure fluids type HEPG (polyalkalene glycol) and HEES (synthetic ester) at operating temperatures up to approx. +70°C .
Purity class	A cleanliness level of at least 20/18/15 is to be maintained according to ISO 4406. When the hydraulic fluid temperature is very high (90°C to 115°C maximum) at the drain port, a cleanliness level of at least 19/17/14 according to ISO 4406 is required.
Cold start	Allowable temperature difference during : between axial piston unit and hydraulic oil $\Delta T \leq 25K$. Starting temperature: $T \geq -25\text{ }^{\circ}\text{C}$ (when the temperature is below $-25\text{ }^{\circ}\text{C}$, NBR shaft seal is required).
Cold start	Viscosity: $v_{\max} \leq 1600\text{mm}^2/\text{s}$, temperature: $\theta_{\text{st}} \geq 25^{\circ}\text{C}$ Remarks: $t \leq 3$ minutes, no load ($20\text{bar} \leq p \leq 50\text{bar}$), $n \leq 1000\text{r}/\text{min}$.

Charge pump (impeller)

The booster pump is driven by the main shaft to replenish oil for the V32G pump, which can achieve a high operating speed, it is also suitable for cold start during low-temperatures and high-viscosity hydraulic oil. For the V32G oil pump that includes a booster pump, **in most cases** there is no need for additional compulsory oil replenishment.

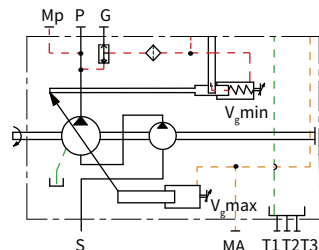

3.1 General

Additional parameters

Designation			145	160	200	300
Min. inlet pressure (absolute) open circuit (Please refer to Figure b on page 11 for specific requirements)		bar	1.0	1.0	1.0	1.0
Minimum operating pressure		bar	Please see Drawing a			
Max. permissible housing pressure (static/dynamic)		bar	2 / 3	2 / 3	2 / 3	2 / 3
Max. permissible inlet pressure (static/dynamic)		bar	20 / 30	20 / 30	20 / 30	20 / 30
Rated rotation speed, at V_{gmax}^*	With impeller	rpm	2600	2500	2400	2000
Max. rotation speed, at $V_g < V_{gmax}$		rpm	Please see Drawing b			
Min. rotation speed in continuous operation		rpm	500	500	500	500
Noise level at 250 bar, 1450 rpm and max. swash plate angle (measured in acoustic measurement chamber according to DIN ISO 4412, measurement distance 1m)		dB (A)	80	80	83	85
Weight (Without through drive, approximate)	With impeller	kg	94	94	113.3	149

- i** Note:
"*)" The data obtained when the absolute pressure p at the oil suction port is absolute=1 bar.
- i** Note:
The minimum operating pressure in the pump line depends on the speed and the pivoting angle; the pressure must not fall below 15 bar under any circumstances.
- i** Note:
The housing pressure is only allowed to be 1 bar higher than the suction pressure, But it cannot exceed the maximum allowable pressure of the shell by 3 bar.

▼ Min. pressure (high-pressure side)

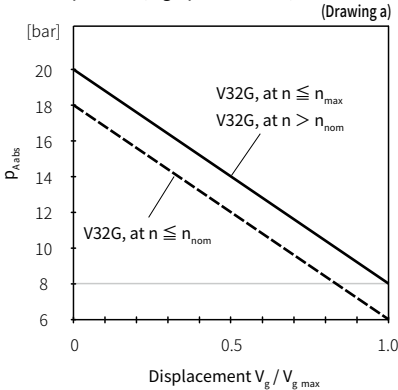

▼ Max. permissible rotational speed (speed limit)

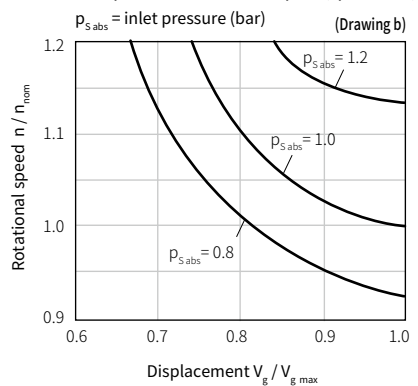

3.1 General

Max. permissible drive/output torque

Designation		Nominal size		
		145/160	200	300
Max. permissible drive torque	Spline shaft D1	3140Nm	3140Nm	-
	Spline shaft D2	-	-	5780Nm
	Spline shaft S6	1640Nm	1640Nm	-
	Spline shaft S7	2670Nm	2670Nm	-
	Straight shaft K	1450Nm	2200Nm	2750Nm
Max. permissible output torque		1100Nm	1300Nm	2200Nm

3.2 Planning information for parameters

Determination of nominal sizes

Delivery flow	$Q = \frac{V_g \cdot n \cdot \eta_v}{1000}$ (lpm)	V_g	= Geom. output volume (cm ³ /rev.)
		Δp	= Differential pressure
Drive torque	$M = \frac{V_g \cdot \Delta p}{20 \cdot \pi \cdot \eta_{mh}}$ (Nm)	n	= Rotation speed (rpm)
		η_v	= Volumetric efficiency
Drive power	$P = \frac{2\pi \cdot M \cdot n}{60000} = \frac{Q \cdot \Delta p}{600 \cdot \eta_t}$ (kw)	η_{mh}	= Mechanical-hydraulic efficiency
		η_t	= Overall efficiency ($\eta_t = \eta_v \cdot \eta_{mh}$)

3.3 Swash angle pick-up

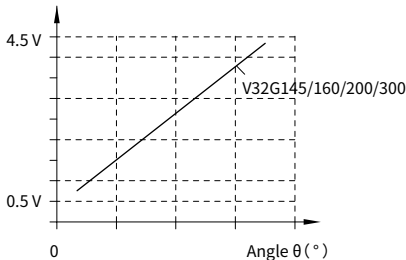

Operating voltage	U_B 10 to 30V DC
Output signal	U_A 0.5 to 4.5V
Tested for automotive field	DIN 40839
Electrical connection	3-PIN AMP
Superseal	1.5 plug

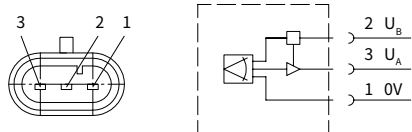

[Continued from Page 13.]

Through the window on the valve plate ⑦, oil suction and pressure can be realized. The control module ④ changes the angle of the swash plate ② by adjusting the control pressure, thereby changing the pump displacement. ⑥ It is an impeller booster pump, which can improve the oil absorption capacity of the pump and allow the pump to operate at a higher speed.

3.4 Section view

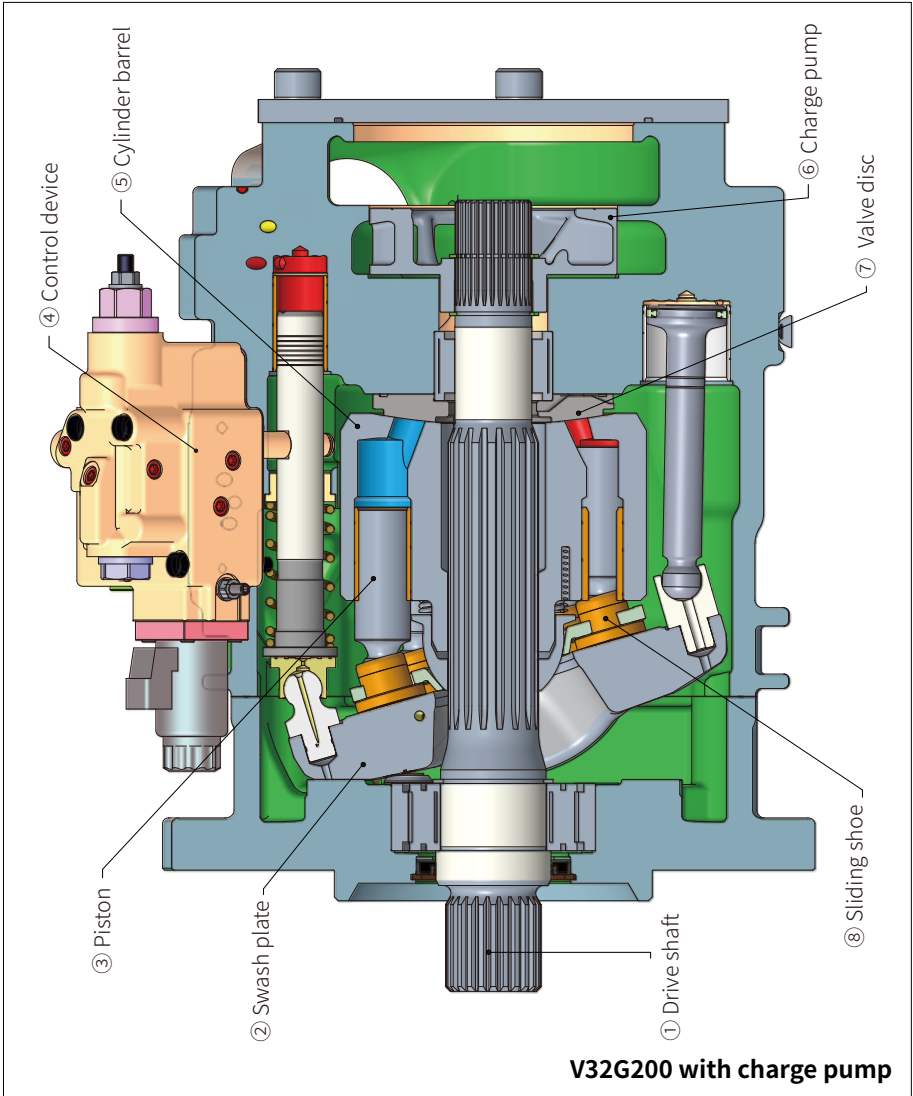

The main shaft ① drives the cylinder block assembly to rotate at a high speed, because the swash plate ② and the cylinder block have a certain angle, while the sliding shoe ⑧ rotates on the swash plate, the plunger ③ reciprocates in the hole of the cylinder block ⑤, so that the plunger is in the cylinder block. The sealing volume in the hole continuously increases and decreases.

[Continue to Page 12.]

3.5 Controller characteristic curves

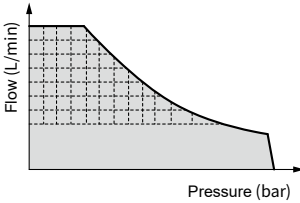

LR – Power control, fixed setting

The power controller regulates the displacement of the pump depending on the working pressure so that a given drive power is not exceeded at constant drive speed.

The power valve adopts Leverage structure, and the output hyperbolic characteristics can accurately control the power, that means :

$P_B \times V_g = \text{constant}$; P_B = working pressure; V_g = displacement.
The hydraulic output power is influenced by the efficiency of the pump.

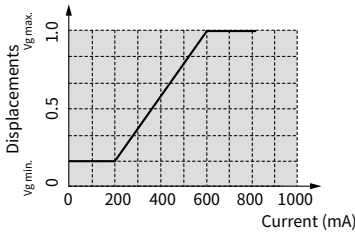

E1 – Electric proportional displacement

Through the proportional electromagnet, the displacement of the pump is in direct proportion (Stepless adjustment) to the current. When there is no current signal, the pump displacement is at the minimum value. As the current increases, the pump displacement becomes larger until it reaches the maximum displacement.

If the pump is to be adjusted from the basic position $V_{g \text{ min}}$ or from a low working pressure, port G must be supplied with an external control pressure of at least 435 psi (30 bar), maximum 725 psi (50 bar).

Technical data, solenoid

Voltage	24 V (± 20 %)	
Control current	Start of control	200 mA
	End of control	600 mA
Current limit	0.75 A	
Nominal resistance	19 Ω	
Dither frequency	120 Hz	
Duty cycle	100 %	
Type of protection	IP69	
Connector for solenoids	DT04-2P	

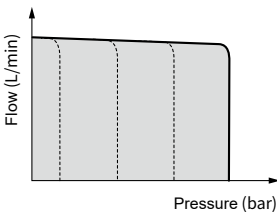

DR – Pressure controller, fixed setting

The pressure controller limits the maximum pressure at the pump outlet within the control range of the variable pump.

The variable pump only supplies as much hydraulic fluid as is required by the consumers. If the working pressure exceeds the pressure command value at the pressure valve, the pump will regulate to a smaller displacement to reduce the control differential.

Basic position in depressurized state: $V_{g \text{ max}}$

Setting range for pressure control: 725 psi to 6100psi (50 bar to 420 bar),

Recommended value: 6100 psi (350 bar).

3.5 Controller characteristic curves

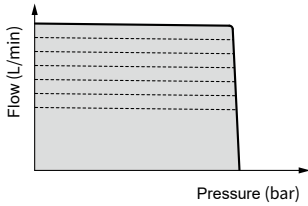

S0 – Load sensing

The load-sensing controller works as a load-pressure controlled flow controller and adjusts the displacement of the pump to the requirements of the actuator.

The load sensing controller compares pressure before and after the metering orifice and keeps the pressure drop (differential pressure Δp) across the orifice – and therefore the flow – constant.

If the differential pressure Δp at the metering orifice rises, the pump displacement reduces. If the differential pressure Δp drops, the pump displacement increases until differential pressure at the metering orifice is restored.

$$\Delta p = P_p - P_a$$

When the pressure setting is reached, cut off the pressure, corresponds to adjust the pump displacement back to the minimum pressure control V_{min} .

The Settable Range of Δp :

Setting range for pressure control: 203 psi to 362 psi (14 bar to 25 bar),

Recommended value: 290 psi (20 bar).

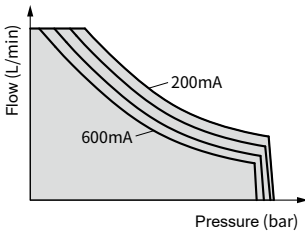

L1 – Electric proportional override

A control current acts against the adjustment spring of the power controller via a proportional solenoid.

Input different currents through electromagnet to control the corresponding output power of the pump, which means:

Increasing control current = reduced power.

The power requirements of different operation modes can be realized.

Technical data, solenoid

Voltage		24 V ($\pm 20\%$)
Control current	Start of control	200 mA
	End of control	600 mA
Current limit		0.75 A
Nominal resistance		19 Ω
Dither frequency		120 Hz
Duty cycle		100 %
Type of protection		IP69
Connector for solenoids		DT04-2P

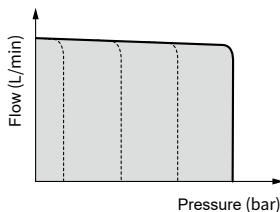

DG – Remote pressure

When this function is not required in use, the pressure difference adjustment screw can be locked clockwise to shield the function.

Setting range for pressure control: 203 psi to 435 psi (14 bar to 30 bar),

Recommended value: 203 psi (14 bar).

4 Dimensions

All dimensions in mm, subject to change!

4.1 V32G 145/160 series

4.1.1 Type V32GL 145/160, clockwise rotation, with charge pump

LRDS — Fixed setting, pressure Cut-off, load sensing

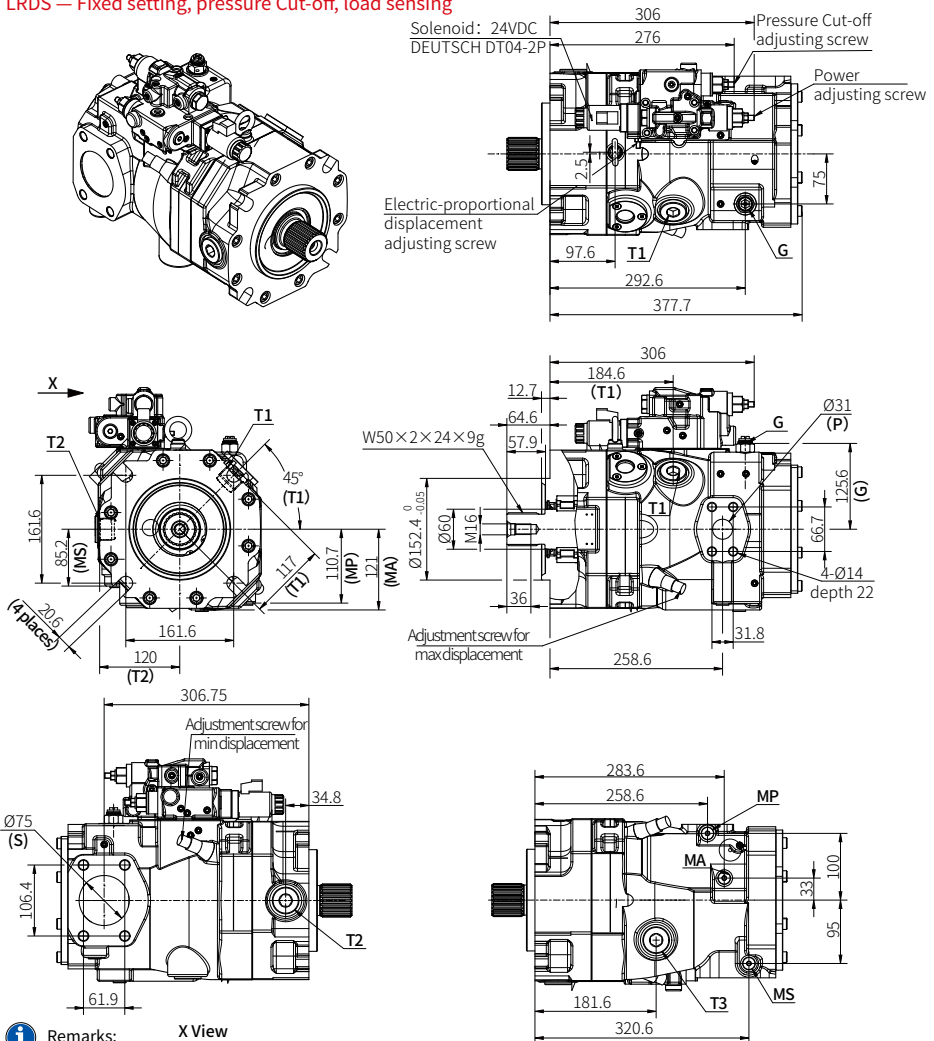

- i** Remarks: X View
 Adjustment screw for min displacement: 0-35 cm³/rev
 Adjustment screw for max displacement: 110-145 cm³/rev

4.1.1 Type V32GL 145/160, clockwise rotation, with charge pump

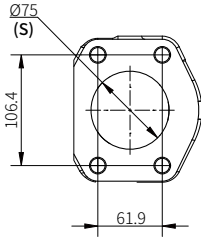

Suction port S

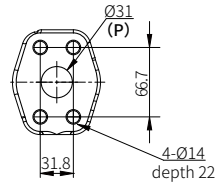

Pressure port P

Shaft version

Spline shaft, Coding D1

(DIN 5480 W50×2×24×9g)

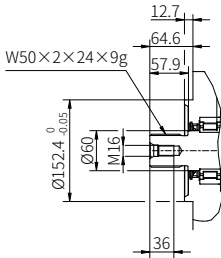

Spline shaft, Coding S6

(SAE J744 13T 8/16 DP)

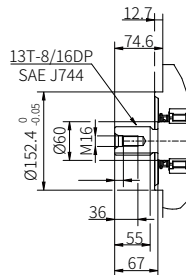

Port details

	Designation	Size	Tightening torque (N.m)
P	Output port	SAE J518 1 1/4in, DIN 13 M14×2, depth 22	157
S	Input port	SAE J518 3in, DIN 13 M16×2, depth 24	246
T1, T2, T3	Drain port	DIN 3852, M33×2, depth 19mm	220
MP	Oil outlet pressure measuring	DIN 3852, M14×1.5, depth 12mm	45
MA	Piston chamber pressure measuring	DIN 3852, M14×1.5, depth 12mm	45
MS	Suction side pressure measuring	DIN 3852, M14×1.5, depth 12mm	45
X	LS Control port	DIN 3852, M14×1.5, depth 12mm	45
G	External control pressure port	DIN 3852, M14×1.5, depth 12mm	45

4.1.2 Type V32GL 145/160, dimension of control mode

LRDRE1

Fixed setting + Electric proportional displacement + Pressure Cut-off.

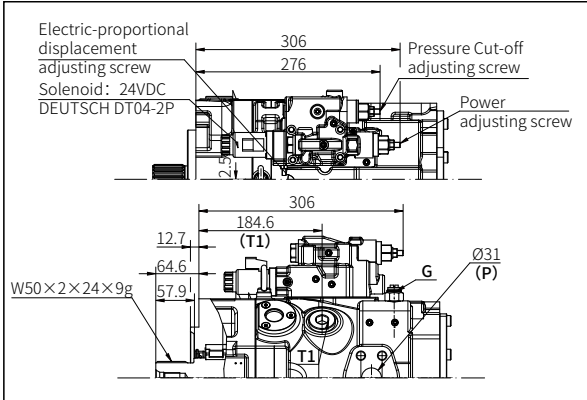

4.2 V32G 200 series

4.2.1 Type V32GL 200, clockwise rotation, with charge pump

LRDRE1 — Fixed setting, electric proportional displacement, pressure Cut-off

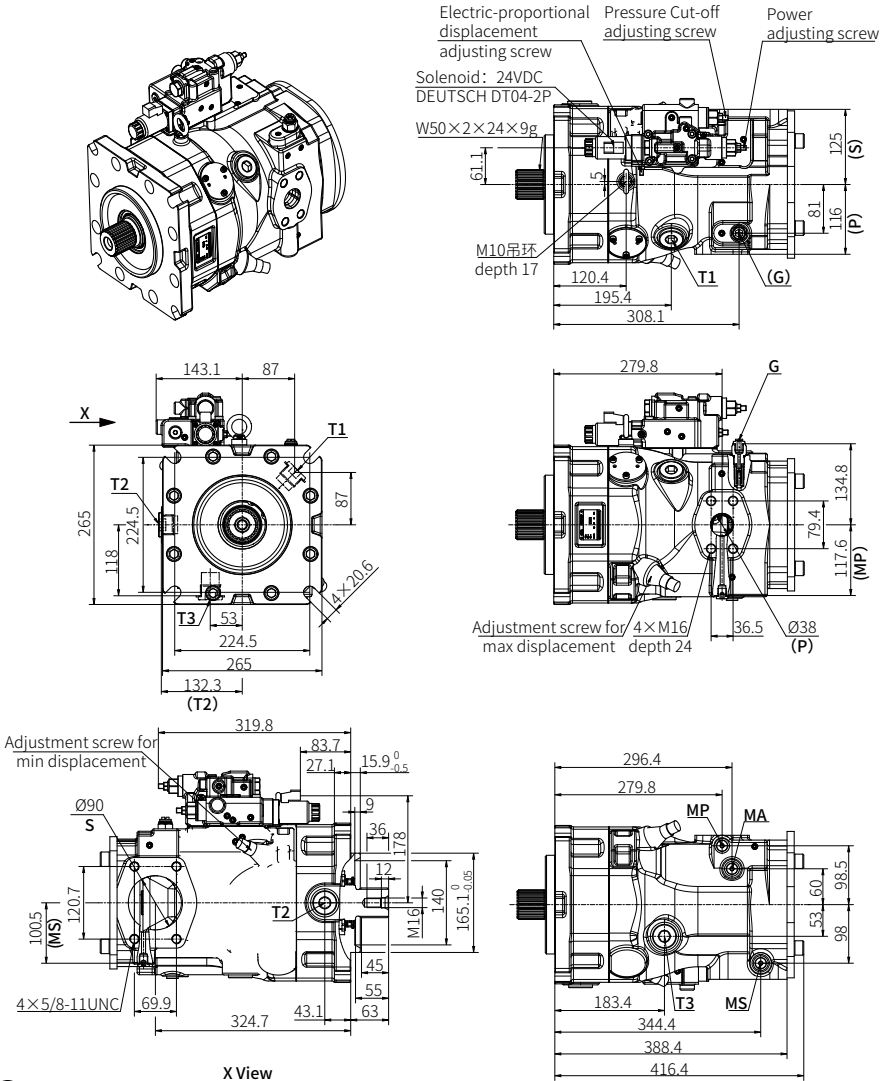

- i** Remarks:
- Adjustment screw for min displacement: 0-50 cm³/rev
 - Adjustment screw for max displacement: 160-200 cm³/rev

4.2.1 Type V32GL 200, clockwise rotation, with charge pump

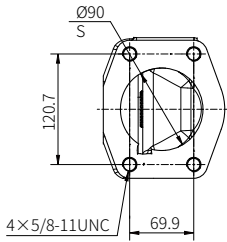

Suction port S

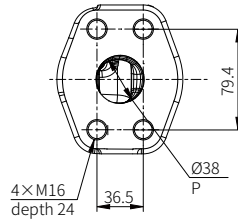

Pressure port P

Shaft version

Spline shaft, Coding D1

(DIN 5480 W50 × 2 × 24 × 9g)

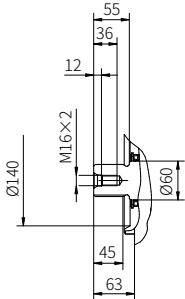

Straight shaft, Coding K3

(Ø55 A 16 × 10 × 100)

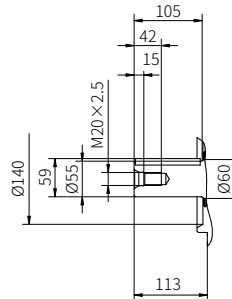

Port details

	Designation	Size	Tightening torque (N.m)
P	Output port	SAE J518C 1 1/2in, DIN 13 M16 × 2, depth 24	240
S	Input port	SAE J518C 3 1/2in, DIN 13 M16 × 2, depth 24	240
T1, T2, T3	Drain port	DIN 3852, M33 × 2, depth 19	220
MP	Oil outlet pressure measuring	DIN 3852, M14 × 1.5, depth 12	45
MA	Piston chamber pressure measuring	DIN 3852, M14 × 1.5, depth 12	45
MS	Suction side pressure measuring	DIN 3852, M14 × 1.5, depth 12	45
X	LS External control pressure port	DIN 3852, M14 × 1.5, depth 12	45
G	External control pressure port	DIN 3852, M14 × 1.5, depth 12	45

4.2.2 Type V32G 200, dimension of control mode

LRDRE1

Fixed setting + Electric proportional displacement + Pressure Cut-off.

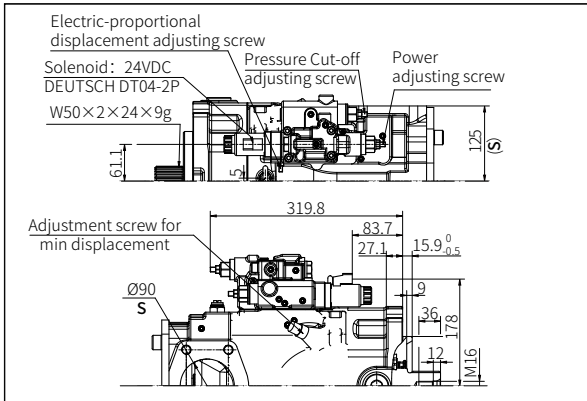

4.3 V32G 300 series

4.3.1 Type V32GL 300, clockwise rotation, with charge pump

LRDRE1 — Fixed setting, electric proportional displacement, pressure Cut-off

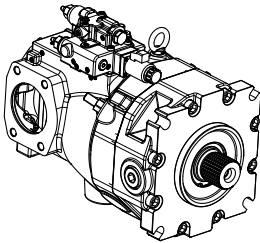

Electric-proportional displacement adjusting screw
 Solenoid: 24VDC DEUTSCH DT04-2P
 Pressure Cut-off adjusting screw
 Power adjusting screw

W60×2×28×9h
 DIN 5480

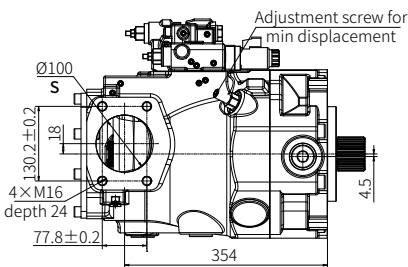
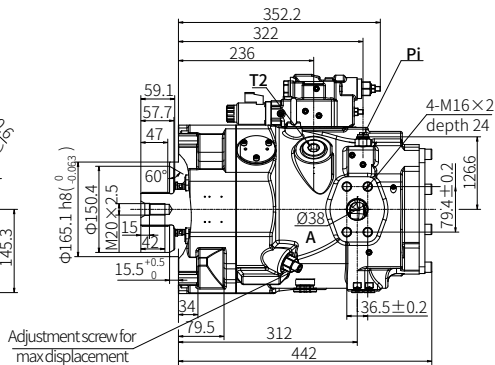
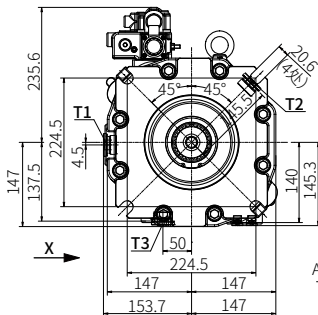
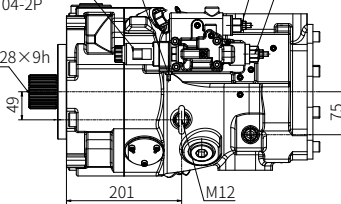

X View

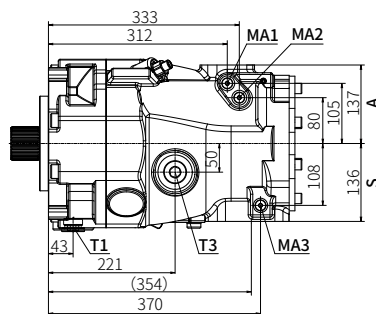

- Remarks:
 Adjustment screw for min displacement: 0-50 cm³/rev
 Adjustment screw for max displacement: 250-300 cm³/rev

4.3.1 Type V32GL 300, clockwise rotation, with charge pump

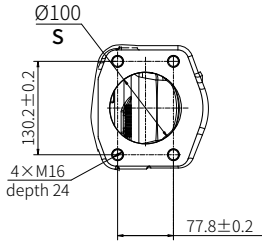

Suction port S

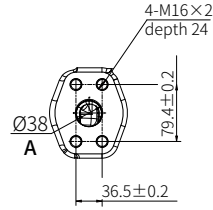

Pressure port P

Shaft version

Spline shaft, Coding D2

(DIN 5480 W60×2×28×9g)

Straight shaft, Coding K4

(DIN 6885 Ø60 A 18×11×100)

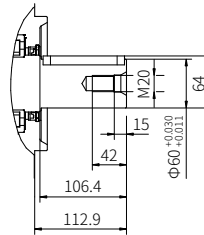
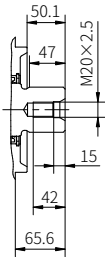

Port details

	Designation	Size	Tightening torque (N.m)
P	Output port	SAE J518 1 1/2in, DIN 13 M16×2, depth 24	240
S	Input port	SAE J518 4in, DIN 13 M16×2, depth 24	240
T1, T2, T3	Drain port	DIN 3852, M33×2, depth 19	220
MP	Oil outlet pressure measuring	DIN 3852, M14×1.5, depth 12	45
MA	Piston chamber pressure measuring	DIN 3852, M14×1.5, depth 12	45
MS	Suction side pressure measuring	DIN 3852, M14×1.5, depth 12	45
G	External control pressure port	DIN 3852, M14×1.5, depth 12	45

4.3.2 Type V32GL 300, dimension of control mode

LRDRE1

Fixed setting + Electric proportional displacement + Pressure Cut-off.

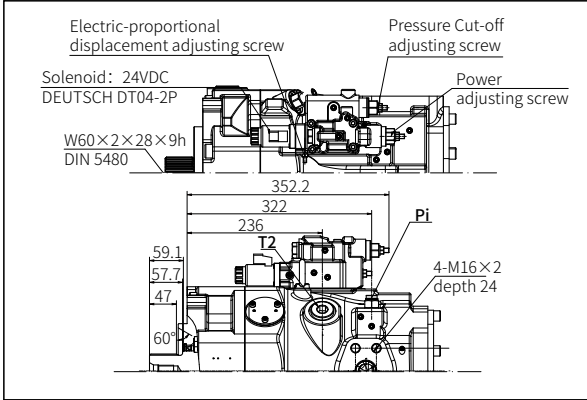

4.4 Through drive

Code	Flange SAE J744	Hub for splined shaft	145/160	205	300
A1	82-2 A	5/8in 9T 16/32DP	●	●	●
A2	82-2 A	3/4in 11T 16/32DP	-	-	-
B1	101-2 B	7/8in 13T 16/32DP	●	●	-
	101-4 B	7/8in 13T 16/32DP	-	●	●
B2	101-2 B	1in 15T 16/32DP	●	●	●
C1	127-2 C	1 1/4in 14T 12/24DP	●	●	-
C2	127-4 C	1 1/4in 14T 12/24DP	●	●	●
D1	152-4 D	1 3/4in 13T 8/16DP	-	●	●
D2	152-4 D	N45×2×21×9g	-	-	-
D3	152-4 D	N50×2×24×9g	●	●	●
E1	165-4 E	2in 15T 8/16DP	-	-	-
E2	165-4 E	N50×2×24×9g	-	●	●
E3	165-4 E	N60×2×28×9g	-	-	●

i Note: ● = Available — = Under development

Flange SAE J744 82-2 (A)

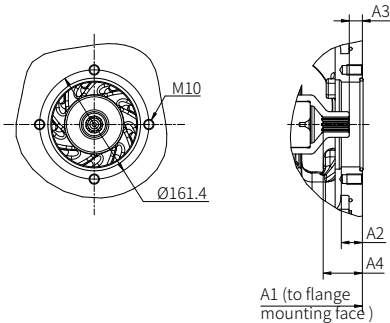

A1			
With charge pump	145/160	205	300
A1	382.85	411.5	433
A2	through hole	15.1	20.5
A3	11.9	12.9	12.8
A4	34.9	35.9	38.1
M (Depth)	M10 depth 16	M10 depth 16	M10 depth 15

Specification of Spline shaft :

A1: 5/8in 9T 16/32DP, SAE J744 16-4(A)

4.4 Through drive

Flange SAE J744 101-2/4(B)

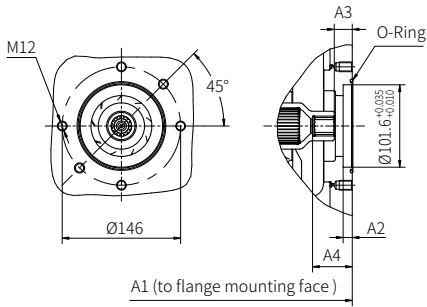

Specification of Spline shaft :

B1: 7/8 in 13T 16/32DP, SAEJ744 22-4(B)

B2: 1 in 15T 16/32DP, SAEJ744 25-4(B-B)

B1

With charge pump	145/160	205	300
A1	377.7	411.5	447.5
A2	11	15.3	11.3
A3	12.5	11.6	29.8
A4	42.5	51.4	51.8
M (Depth)	M12 depth 18	M12 depth 16	M12 depth 16

B2

With charge pump	145/160	205	300
A1	377.6	411.5	447.5
A2	11	15.3	11.3
A3	13.5	11.5	22.3
A4	47.6	48.4	49
M (Depth)	M12 depth 18	M12 depth 16	M12 depth 16

Flange SAE J744 127-2/4(C)

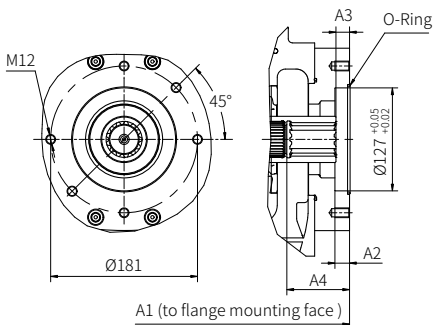

C1

With charge pump	145/160	205	300
A1	388	415.4	-
A2	14	10.9	-
A3	20.65	13	-
A4	64	55.4	-
M (Depth)	M12 depth 28	M12 depth 18	-

Specification of Splined shaft :

C1: 1 1/4in 14T 12/24DP, SAE J744 32-4(C)

4.4 Through drive

Flange SAE J744 127-4(C)

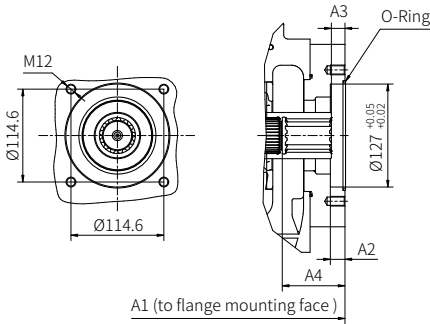

C2			
With charge pump	145/160	205	300
A1	387.7	414.4	463
A2	14	13	18
A3	17.5	10.9	16.8
A4	58	55.4	58
M (Depth)	M12 depth 28	M12 depth 16	M12 depth 18

Specification of Splined shaft :

C2: 1 1/4in 14T 12/24DP, SAEJ744 32-4(C)

法兰 SAE J744 152-4(D)

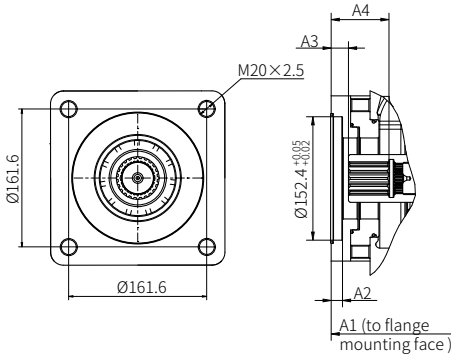

D1			
With charge pump	145/160	205	300
A1	-	436.4	463
A2	-	14	17
A3	-	21.4	31.8
A4	-	56	77.3
M (Depth)	-	M12 depth 24	M12 depth 43

Specification of Splined shaft :

D1: 1 3/4in 13T8/16DP, SAE J744 44-4(D&E)

Flange SAE J744 152-4(D)

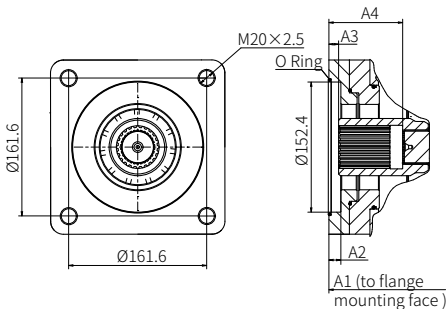

D3			
With charge pump	145/160	205	300
A1	399.5	436.5	456
A2	14	11	17
A3	14.7	11.4	23.3
A4	76.7	75	73.8
M (Depth)	M20 (through hole)	M20 depth 24	M20 depth 36

Specification of Splined shaft :

D3: N50×2×24×9g DIN5480

4.4 Through drive

Flange SAE J744-165-4(E)

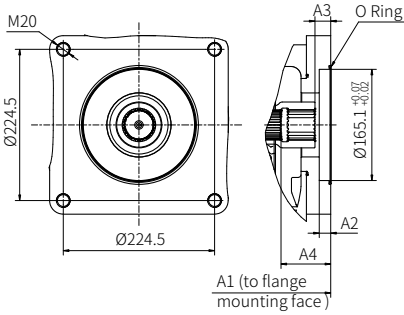

Specification of Splined shaft :

E2: N50×2×24×9g DIN5480

E3: N60×2×28×9g DIN5480

E2

With charge pump	145/160	205	300
A1	-	416.4	456
A2	-	19	17
A3	-	17.4	23.3
A4	-	65.4	73.8
M (Depth)	-	M20 depth 28	M20 depth 36

E3

With charge pump	145/160	205	300
A1	-	-	456
A2	-	-	17
A3	-	-	19.8
A4	-	-	73.8
M (Depth)	-	-	M20 depth 36

5 Installation information

5.1 General

The V32G variable displacement axial piston pump is designed for use in an open circuit.

The following essential points must be noted when installing the pump:

Mounting and removal of the pump and attached components may be performed by trained persons only. Ensure absolute cleanliness during all work. Contamination may have an adverse effect on the function and service life of the pump.

- Remove all plastic plugs prior to initial operation.
- Avoid installing the motor above the tank (see [Chapter 5.3, "Installation positions"](#)).
- Observe the reference values in Section .
- Prior to initial operation, fill the pump with oil and bleed.
Automatic pump filling via the suction line by opening the drain ports is not possible.
- Prevent the pump and suction line from running dry.
- Always ensure a constant supply of oil.
Even a brief shortage in the supply of hydraulic fluid to the pump may damage internal parts.
This may not be immediately evident after initial operation.
- The hydraulic oil returning to the tank from the system must not be sucked back in immediately (baffles).
- Run the pump for approx. 10 minutes at max. 50 bar after initial operation.
- Thorough bleeding/flushing of the entire system is recommended before the full pressure range is used.
- Observe the max. permissible operating range temperatures (see [Chapter 3, "Parameters"](#)) at all times.
- Always comply with the specified oil purity classes (see [Chapter 3, "Parameters"](#));
provide appropriate hydraulic fluid filtering.
- Use of a filter in the suction line must be approved by InLine Hydraulik.
- Include a main pressure-limiting valve in the pressure line to limit the max. system pressure.

5.2 Installation positions

The variable displacement axial piston pump V32G can be installed as follows:

Horizontal installation: (pump below the min. fill level)

For horizontal installation, use the uppermost drain port.

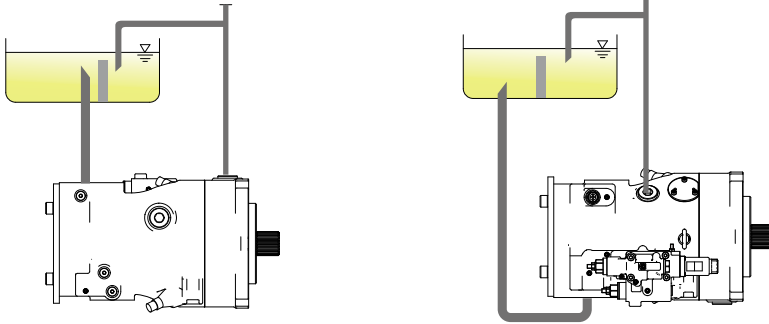

Vertical installation: (pump below the min. fill level)

Mount the pump so that the pump mounting flange is facing upwards.

For vertical installation, use the uppermost drain port.

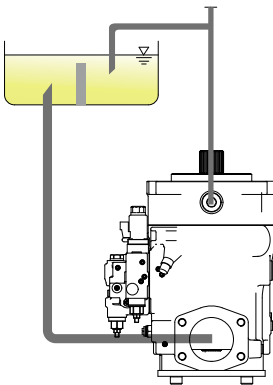

5.3 Tank installation

Tank installation (pump below the min. fill level)

The pump can be operated either with or without a suction tube. Using a short suction intake is recommended.

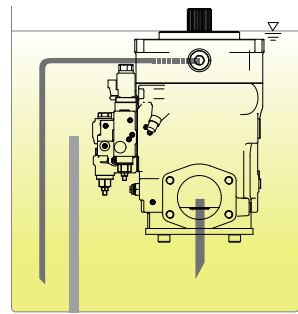
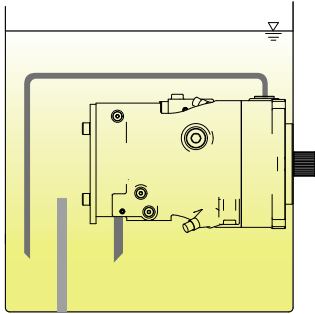

Additional notes regarding installation above the fill level

Special measures are required if the pump is installed above the fill level. The pump must not run dry via the pressure, intake, drain, bleed or control lines. This applies in particular to long periods of downtime.

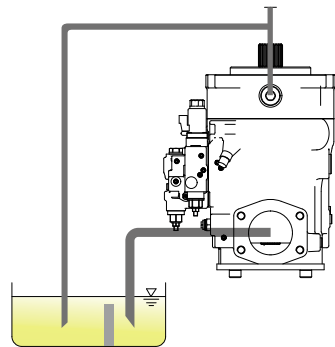
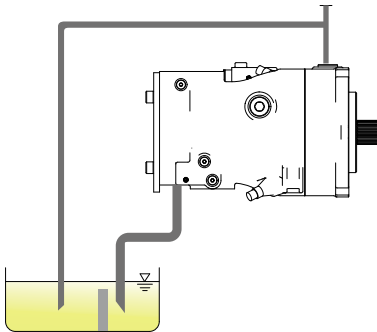

6 Installation, operation and maintenance information

6.1 Designated use

This fluid-power product has been designed, manufactured and tested acc. to standards and regulations generally applicable in the European Union and left the plant in a safe and fault-free condition.

To maintain this condition and ensure safe operation, operators must observe the information and warnings in this documentation.

This fluid-power product must be installed and integrated in a hydraulic system by a qualified specialist who is familiar with and adheres to general engineering principles and relevant applicable regulations and standards.

In addition, application-specific features of the system or installation location must be taken into account if relevant.

This product may only be used as a flow control valve as a pump within oil-hydraulic systems.

The product must be operated within the specified data. This documentation contains the technical parameters for various product versions.



Note:

Non-compliance will void any warranty claims made against InLine Hydraulik GmbH.

6.2 Assembly information

The hydraulic accumulator must be integrated in the system via state of the art connection components (screw fittings, hoses, pipes, etc.). The hydraulic system must be shut down as a precautionary measure prior to dismantling; this applies in particular to systems with hydraulic accumulators.

© by InLine Hydraulik GmbH.

The forwarding and reproduction of this document, as well as the use and communication of its contents, are forbidden unless expressly permitted.

Any breach or infringement will result in liability for damages.

All rights reserved concerning patent or utility model registrations.



Jiangsu Hengli Hydraulic Co., Ltd.

Add: No.99 Longqian Road, Wujin District,
Changzhou 213167, China

Tel: +86 400 101 8889

Fax: +86 519 8615 9988

hengli@henglihydraulics.com

www.henglihydraulics.com



InLine Hydraulik GmbH

Add: Spenberger Straße 13 D-12277 Berlin

Tel: +49 (30) 72088-0

Fax: +49 (30) 72088-44

info@inlinehydraulik.com

www.inlinehydraulik.com



Management Service