



4.5

M70V SERIES

Swash-plate Type Axial Piston Variable Displacement Motor

M70V series swashplate axial piston motor is the variable displacement motor with wide application for open and closed circuit. The swashplate design allows a compact motor with high power density. This series is applicable to construction machinery and industrial vehicles.

Apply to open and closed hydraulic circuit

Displacements (cc/rev) 112

Rated pressure (bar): 400

Maximum pressure(bar): 450



Contents

Technical data	02
Type introduction	03-04
Precautions for system design	05
Hydraulic Circuit	06
Installation size	
· M70V 112 Installation size	07
· Port and flange fixing thread	08
· Port details	08
· Input Shaft	09

Features

- **High speed operation and smooth starting characteristics:**
Optimized rotary balance design high-speed performance and excellent starting characteristics.
- **Low speed operation:**
Superior performance in low speed operation provides excellent controllability.
- **Compact size:**
Swash plate conuguration provides the more compact structure and exhibity in system design.
- **Long bearing life:**
Swash plate conuguration results in longer bearing life.

Technical Data

Size		M70V 112
Min. Displacement: q_{\min}	cc/rev	0 ~ 90
Max. Displacement: q_{\max}	cc/rev	90 ~ 112
Max. speed: $N_{\text{nom}}/N_{\text{max}}$ *1	rpm	3550/5600
Rated pressure: P_{nom} *2	bar	400
Max. Pressure: P_{max}	bar	450
Theoretical output torque	N·m	713
Power	Kw	265
Max. Flow: Q	L/min	398
Moment of inertia	kg.m ²	0.015
Volume in the case	L	1
Mass	Kg	46
Temperature	°C	at drain port: -20 ~ +115 at inlet port: -20 ~ +90

Note:

*1: N_{nom} : Max. speed at q_{\max}

N_{max} : Max. speed at $q < 0.6q_{\max}$

*2: Rated pressure corresponds to the design pressure to provide proper performance, function, and service life.

Type introduction

M70V	112	A	D	4	3	-	A	Y	1	H1	B1	X	X	N	-	01
①	②	③	④	⑤	⑥		⑦	⑧	⑨	⑩	⑪	⑫	⑬	⑭		⑮

Product series

①	Product series	M70V
---	----------------	------

Size

②		112
	Standard size	●

Design series

③	Standard series	A
---	-----------------	---

Mounting flange and port position

	Mounting	Port Position	112	Code
④	SAE J744, 4-bolt Mount	Rear	○	A
	SAE J744, 4-bolt Mount	Side	○	B
	ISO3019-2, 4-bolt Mount	Rear	○	C
	ISO3019-2, 4-bolt Mount	Side	●	D

Port and flange fixing thread

	Threaded port type	Flange fixing thread type	112	Code
⑤	ANSI ISO 11926	ANSI ASME B1.1	○	1
	ANSI ISO 11926	Metric ISO 724	○	2
	Metric ISO 6149	Metric ISO 724	○	3
	Parallel Piping ISO 228	Metric ISO 724	●	4

Input shaft

	Standard	Specifications	112	Code
⑥	ANSI B 92.1	1 3/4 in 13T 8/16DP	○	1
	DIN 5480	W45×2×21×9g	○	2
	DIN 5480	W40×2×18×9g	●	3

Max. displacement

⑦	112	A
	107	B
	100	C
	95	D

Type introduction

Min. displacement

⑧		Code
	68	A
	50	B
	40	C
	30	D
	22	E

Speed Sensor

⑨		112	Code
	Without speed sensor	●	1
	With speed sensor	○	2

Control type

⑩	Pressure related control	H1
---	--------------------------	----

Optional valves

⑪	Two position displacement control	With Electric Two-Position Control Valve, 24V	B1
---	-----------------------------------	---	----

Accessories

⑫	Without Any Accessory	X
---	-----------------------	---

Counter balance valve

⑬	Without Counter Balance Valve	X
---	-------------------------------	---

Response Speed of Control

⑭	Standard	N
---	----------	---

Design Code

⑮	01 ~	**
---	------	----

Precautions for System Design

Minimum boost pressure

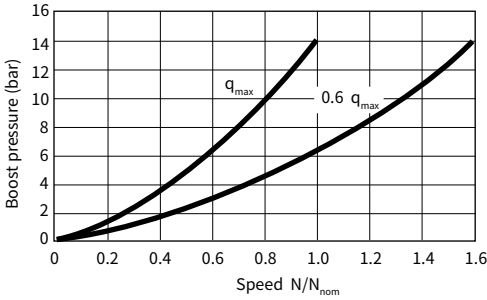

- Minimum boost pressure

To prevent cavitation when the motor is operating in a pumping mode, a positive pressure is required at the suction port. The figure on the right shows the minimum boost pressure requirement based on the regular operation. In case of a rapid change of the flow volume, more boost pressure must be applied.

Minimum back pressure

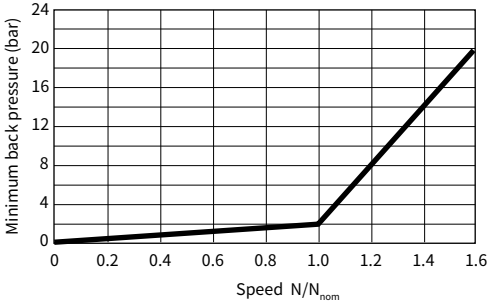

- Minimum back pressure

To ensure the optimal performance and life time the back pressure is required at the lower pressure port. Motor casing pressure must be ≤ 2 bar.

Permissible displacement

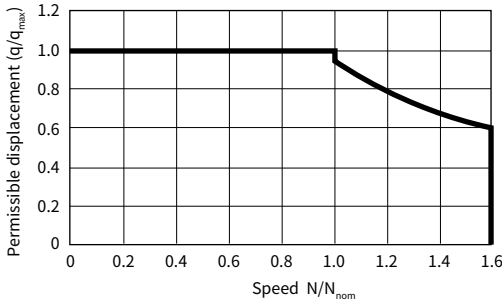

- Permissible Displacement, Speed Related

The figure on the left shows permissible displacement in relation to the motor operating speed. Design the system not to exceed this requirement.

Hydraulic Circuit

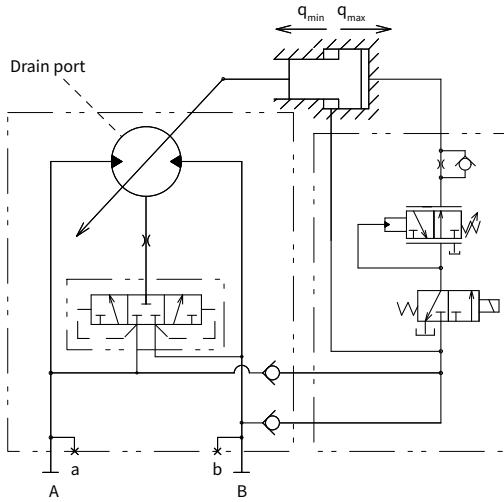

Solenoid Specifications

Voltage	DC 24V
Resistance	23.5 Ω
Connector type	Deutsch DT04-2P

Installation size

M70V 112 Installation size

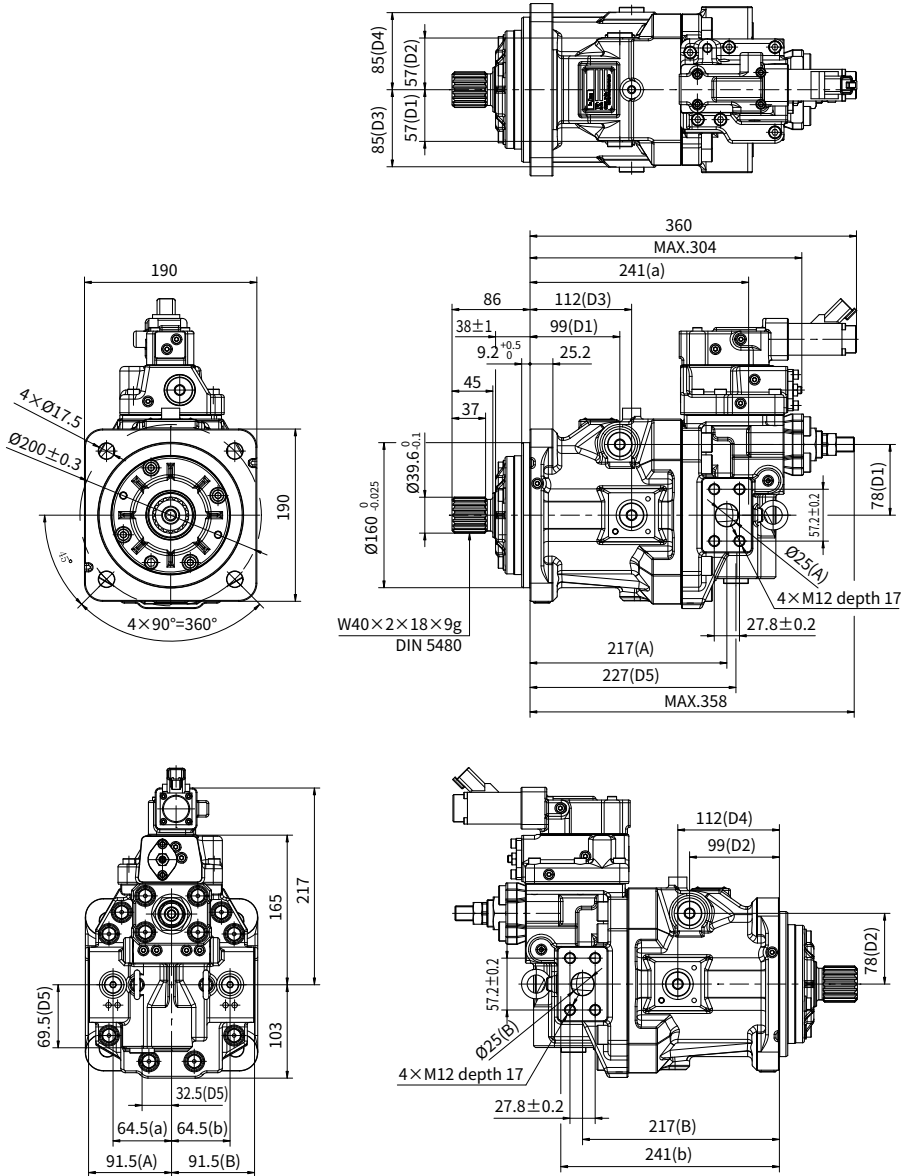

04

Installation size

· Port and flange fixing thread

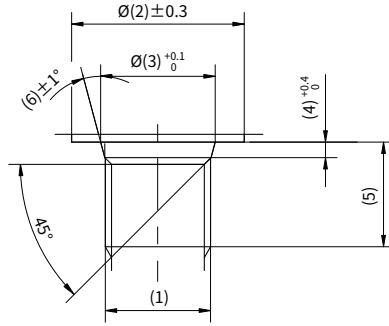

Thread Port

· ANSI thread type (Code : 1, 2)

	Symbol	(1)	(2)	(3)	(4)	(5)	(6)	Tightening torque (N.m)
Gauge port	a, b	9/16-18UNF-2B	25	15.6	2.5	12.7	12	59
Pilot port	Pi	9/16-18UNF-2B	25	15.6	2.5	12.7	12	59
Drain port	D1 ~ D5	1-1/16-12UN-2B	41	29.2	3.3	12.7	15	170

· Metric thread type (Code : 3)

	Symbol	(1)	(2)	(3)	(4)	(5)	(6)	Tightening torque (N.m)
Gauge port	a, b	M14×1.5	25	15.6	2.4	12.5	15	47
Drain port	D1 ~ D5	M27×2	40	29.4	3.1	12.7	15	180

· Parallel piping thread type (Code : 4)

	Symbol	(1)	(2)	(3)	(4)	(5)	(6)	Tightening torque (N.m)
Gauge port	a, b	G 1/4	25	15.6	2.5	15	15	36
Pilot port	Pi	G 1/4	25	15.6	2.5	15	15	36
Drain port	D1 ~ D5	G 1/2	34	22.6	2.5	12.7	15	108

Installation size

• Port details

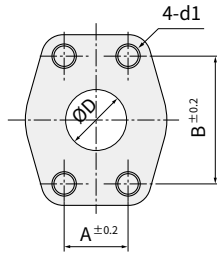

• ANSI thread type (Code : 1, 2)

Port thread type code	d1	A	B	D	Tightening torque (N.m)
1	7/16-14UNC-2B	27.8	57.2	25	98
2, 3, 4	M12	27.8	57.2	25	98

• Input Shaft

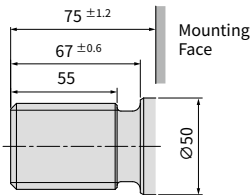

Code: 1

ANSI B92.1a
(1 3/4in 13T 8/16DP)

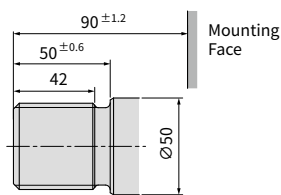

Code: 2

DIN 5480
(W40×2×18×9g)

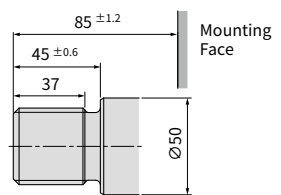

Code: 3

DIN 5480
(W45×2×21×9g)

China

+86 400 101 8889

America

+01 630 995 3674

Germany

+49 (30) 72088-0

Japan

+81 03 6809 1696



© This brochure can be reproduced, edited, reproduced or transmitted electronically without the authorization of Hengli Hydraulic Company. Due to the continuous development of the product, the information in this brochure is not specific to the specific conditions or applicability of the industry, thus, Hengli does not take any responsibility for any incomplete or inaccurate description.