



1.1

HVSH SERIES

OPEN CENTER CONTROL DIRECTIONAL VALVE

HVSH :

Nominal size	14	14A	16D	16B	20
Rated flow(L/min)	70	30/70	80	90	160
Max. pressure(bar)	315	315	315	315	315
Control electric voltage (VDC)	12/24	12/24	12	12	-

Benefits:

- Low pressure drop, more energy-efficient
- Sandwich plate structure or monoblock design, flexible adjustment
- Emergency valve, prevent misuse
- Small and light

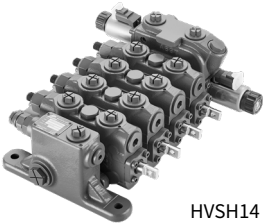

HVSH14 (片式)

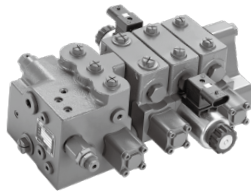

HVSH14A (片式)



HVSH16D (片式)

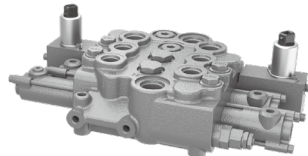

HVSH16B (整体式)

Contents

	Page
Features	03
HVSH14	
· Section view	04
· Characteristic curves	05
· Hydraulic diagram	06
· Ordering code	07
· Unit dimensions	08
HVSH14A	
· Section view	14
· Hydraulic diagram	15
· Ordering code	16
· Unit dimensions	17
HVSH16D	
· Section view	19
· Hydraulic diagram	20
· Ordering code	21
· Unit dimensions	22
HVSH16B	
· Section view	28
· Hydraulic diagram	29
· Unit dimensions	30
HVSH20	
· Section view	32
· Hydraulic diagram	33
· Ordering code	34
· Unit dimensions	35

Features

1. Structure

- Sandwich plate of design (HVSH14, HVSH14A, HVSH16D, HVSH20)
- Monoblock design (HVSH16B)

2. Control

- Electro-hydraulic control (HVSH14, HVSH14A, HVSH16B)
- Manual control (HVSH14, HVSH14A, HVSH16D, HVSH20)
- Hydraulic operation (HVSH14, HVSH20)

3. Applications



Hooklift



Wrecker



Sweeper



Compression vehicle



Skid steer loader



Backhoe loaders



Tractor
(HVSH16D)



Rice harvester
(HVSH14A)

4. Technical characteristics (The HVSH16D is used in tractors)

- Mechanical lifter with mechanical holding function.
- The mechanical elevator is connected with the lift positioning + automatic reset function
- Mechanical lifter with floating positioning function.
- Optional electro-hydraulic lift taillink.
- Port B is equipped with single and double acting switching valve.

Section view

· HVSH14 Electro-hydraulic control

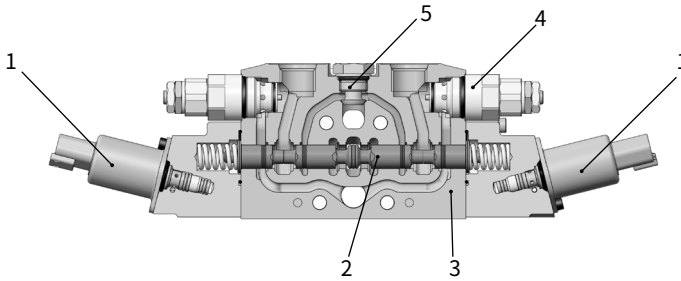

· HVSH14 Manual contro

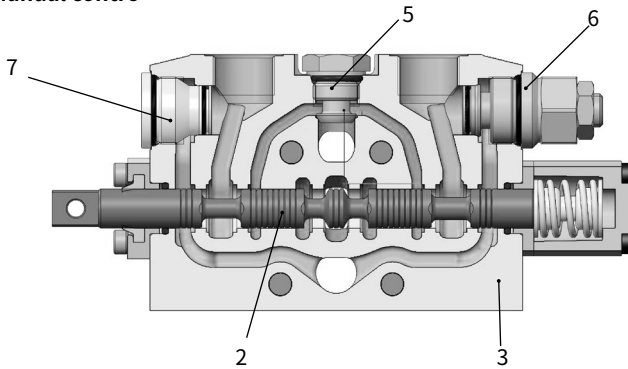

· HVSH14 Hydraulic operation

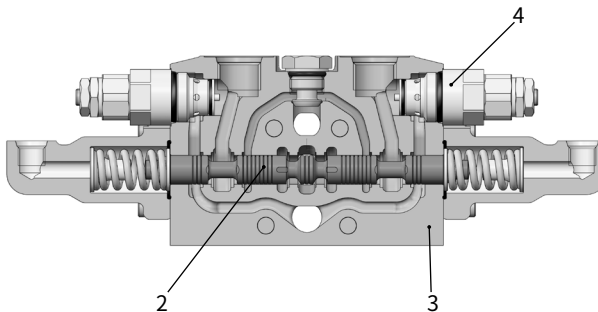

1 Solenoid Valve

2 Spool

3 Valve block

4 Relief valve

5 Check valve

6 Single and double acting
switching valve

7 Plug

Characteristic curves

· Pressure drop characteristic curve (HVSH14)

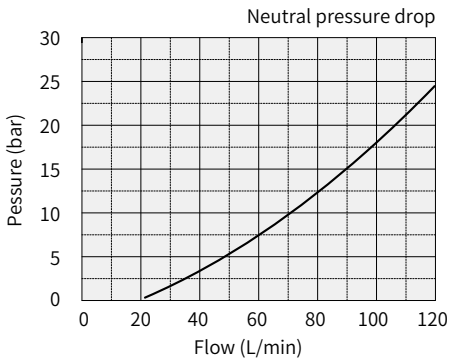
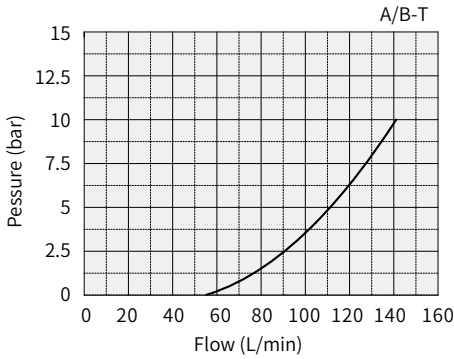
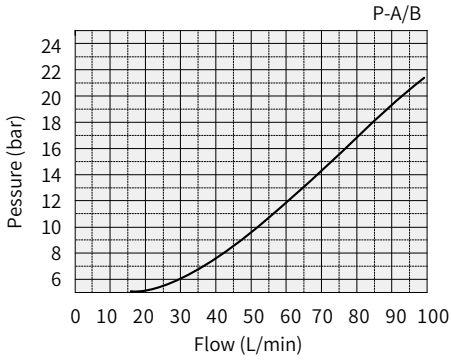

01

Hydraulic diagram

· HVSH14 Electro-hydraulic control

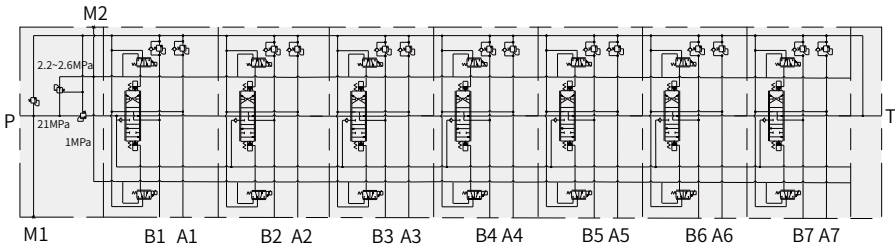

· HVSH14 Hydraulic operation

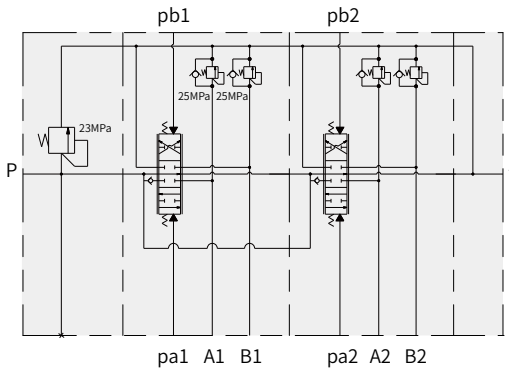

· HVSH14 Manual contro

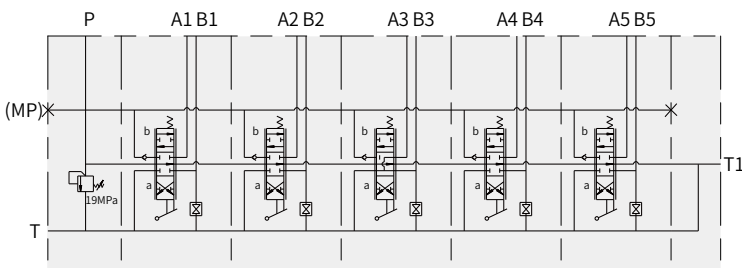

Ordering code

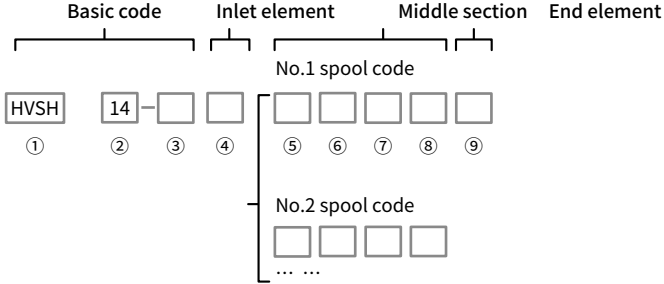

Ordering details: HVSH14 - 03 - P220 - $\left[\begin{array}{l} \text{O150PH} \\ \text{YP150M} \\ \text{Y150SM} \end{array} \right] - \text{N}$

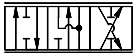
Basic code	① Structure	HVSH	Sandwich plate design
	② Nominal size		14
	③ Number of directional middle sections		01-07
Inlet element	④ Main relief valve	P***	With main relief valve, setting pressure, 3- digits, bar
		C	Without main relief valve
Middle directional section	⑤ Spool function	O	O Type 
		Y	Y Type 
	⑥ Relief valve at A side	***	With relief valve, setting pressure, 3- digits, bar
		P	With plug
	⑦ Relief valve at B side	***	With relief valve, setting pressure, 3- digits, bar
		P	With plug
		S	Single-double action switch (Available in mechanical control link only)
	⑧ * Operation type	E	Electro-hydraulic control
H		Hydraulic operation	
M		Manual contro	
Endlet section	⑨ carry-over function	N	Without carry over
*	Other request	Further requirement in the clear text	

Unit dimensions

· HVSH14 Electro-hydraulic control

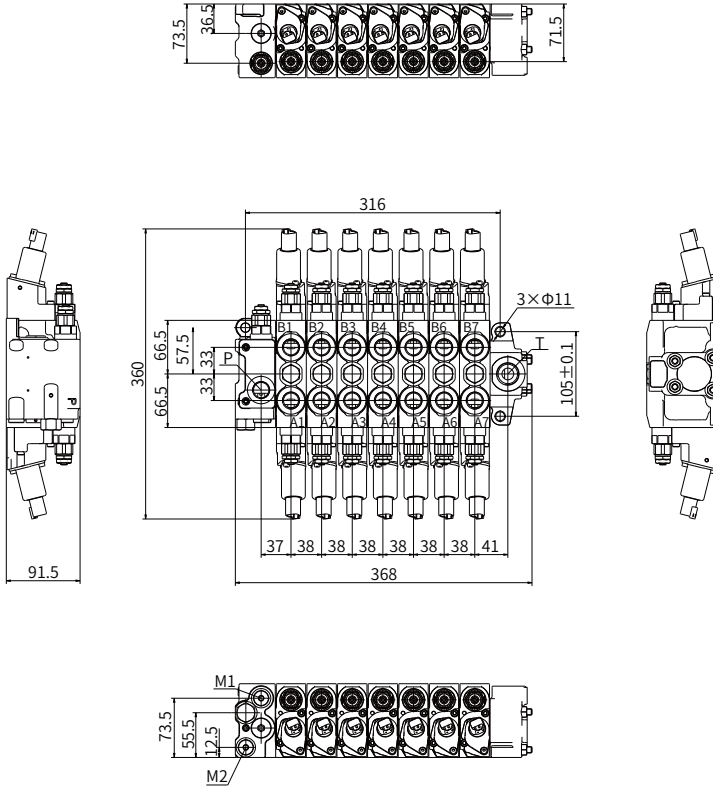

Port connection

·HVSH14 Electro-hydraulic control

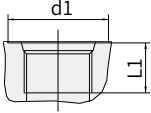
	HVSH14	Port JIS B 2351		Thread	d1	L1
		P	Inlet port	G1/2	34	16
		T	Outlet port	G3/4	43	17
		A/B	Work port	G1/2	34	16
		MP	Other oil orifice	G1/4	24	15

01

Unit dimensions

· HVSH14 Hydraulic operation

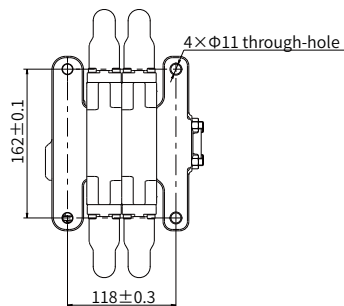
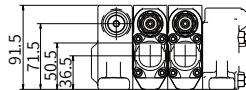
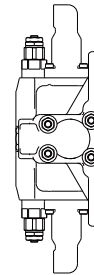
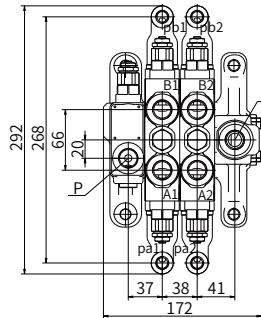
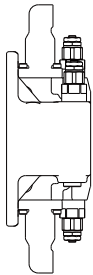
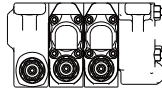

Port connection

· HVSH14 Hydraulic operation

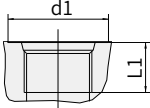
	HVSH14	Port JIS B 2351		Thread	d1	L1
		P	Inlet port	G1/2	34	16
		T	Outlet port	G3/4	43	17
		A/B	Work port	G1/2	34	16
		pa/pb	Pilot port	G1/4	24	15
		M1	Other oil orifice	G1/4	24	15

01

Unit dimensions

· HVSH14 Manual contro

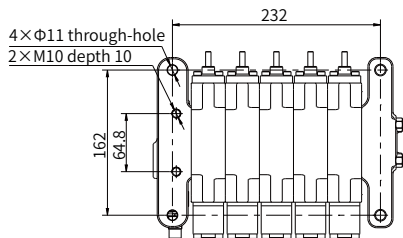
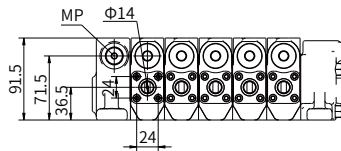
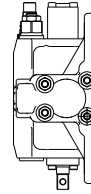
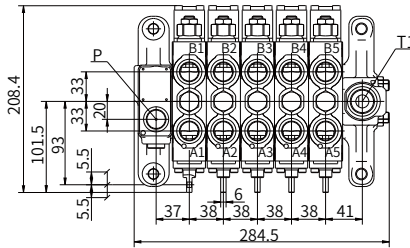
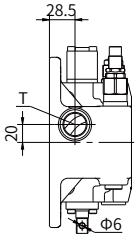
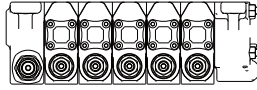

Port connection

· HVSH14 Manual contro

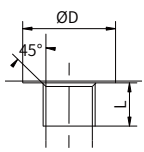
	HVSH14	Port ISO 9974		Thread	ΦD	L1
		P	Inlet port	M22*1.5	28	14
		T	Outlet port	M27*2	33	16
		A/B	Work port	M22*1.5	28	14
		MP	Other oil orifice	M14*1.5	20	12

01

Section view

· HVSH14A Electromagnetic direct thrust

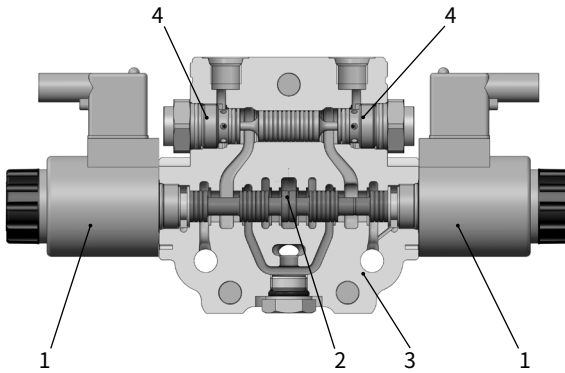

· HVSH14A Manual contro

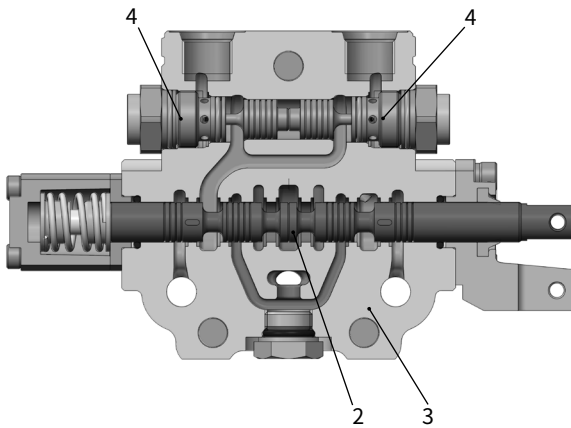

1 Electromagnet

2 Spool

3 Valve block

4 Check valve

Hydraulic diagram

· HVSH14A

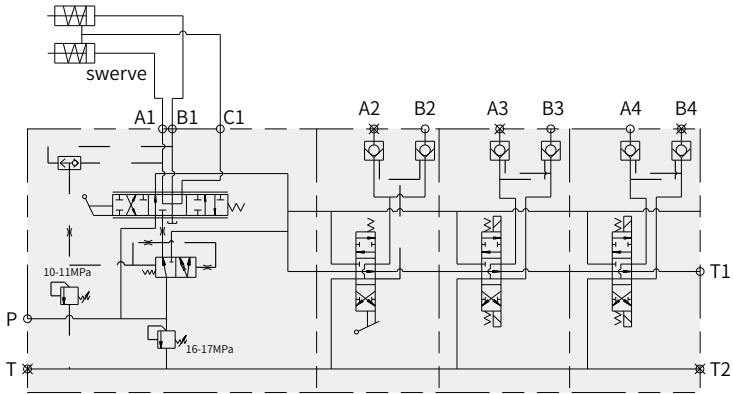

Ordering code

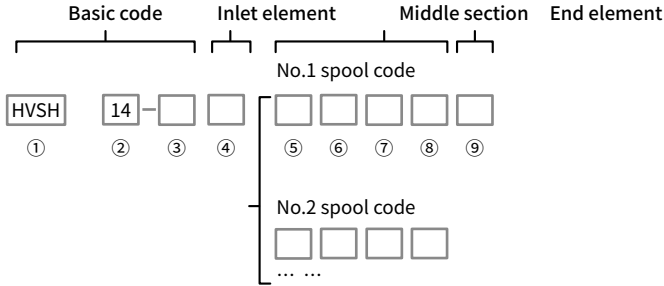

Ordering details: HVSH14A - 03 - P220 - $\left[\begin{array}{l} \text{O150PM} \\ \text{YQQE} \\ \text{YQQE} \end{array} \right] - \text{HN}$

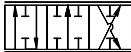
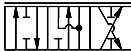
Basic code	① Structure	HVSH	Sandwich plate design
	② Nominal size		14A
	③ Number of directional middle sections		01-07
Inlet element	④ Main relief valve	P***	With main relief valve, setting pressure, 3- digits, bar
Middle directional section	⑤ Spool function	O	O Type 
		Y	Y Type 
	⑥ Relief valve at A side	***	With relief valve, setting pressure, 3- digits, bar
		P	With plug
		Q	Hydraulic lock (A and B should be selected at the same time)
	⑦ Relief valve at B side	***	With relief valve, setting pressure, 3- digits, bar
		W	With plug
		P	With plug
	⑧ * Operation type	Q	Hydraulic lock (A and B should be selected at the same time)
E		Electromagnetic direct thrust (Maximum flow: 30L/min)	
Endlet section	M	Manual contro (Maximum flow: 70L/min)	
	⑨ carry-over function	N	Without carry over
*	Other request	Further requirement in the clear text	

Unit dimensions

· HVSH14A

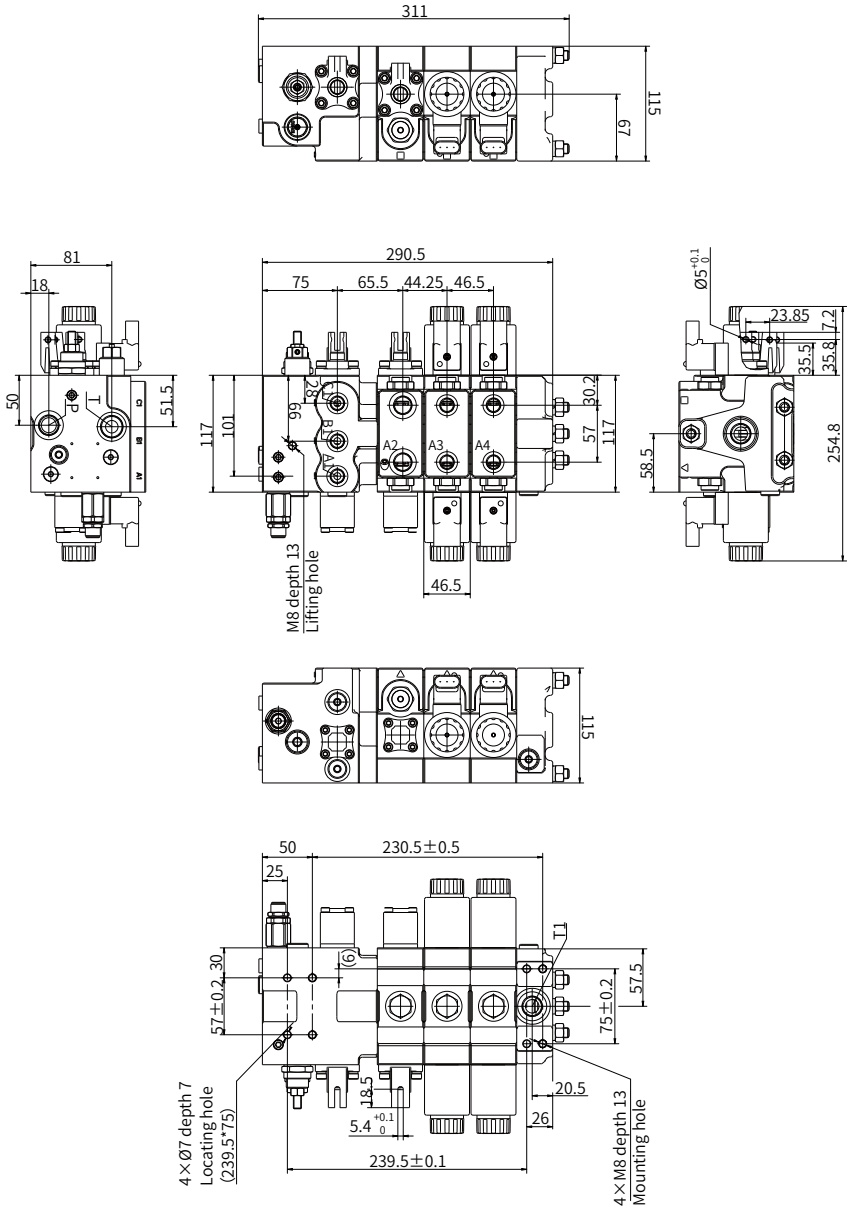

Port connection

· HVSH14A

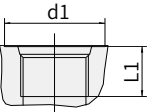
	HVSH14A	Port ISO 6149		Thread	d1	L1
		P	Inlet port	M20*1.5	29	14.5
		T	Outlet port	M22*1.5	34	15.5
		T1, T2		M20*1.5	29	14.5
		A/B	Work port	M14*1.5	21	11.5
			27	14.5		

01

Section view

·HVSH16D

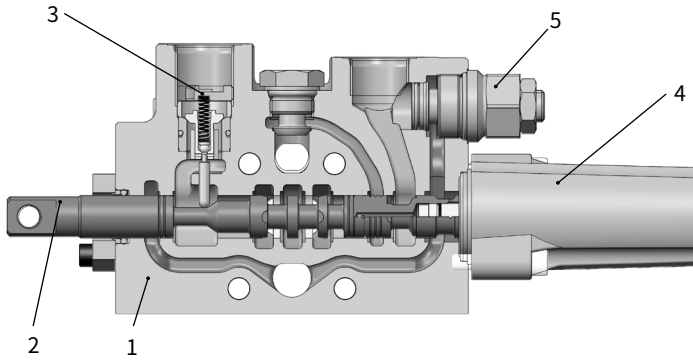

1 Valve block

2 Spool

3 Mechanical holding valve

4 Rise positioning + automatic reset

5 Single and double acting switching valve

Hydraulic diagram

• HVSH16D CAN bus motor

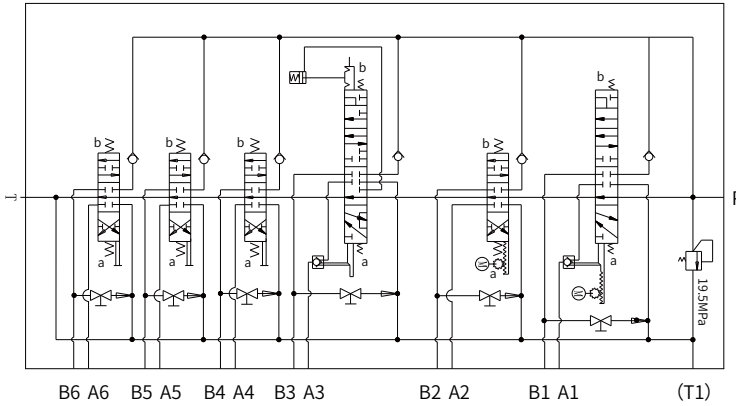

• HVSH16D Electro-hydraulic lifting

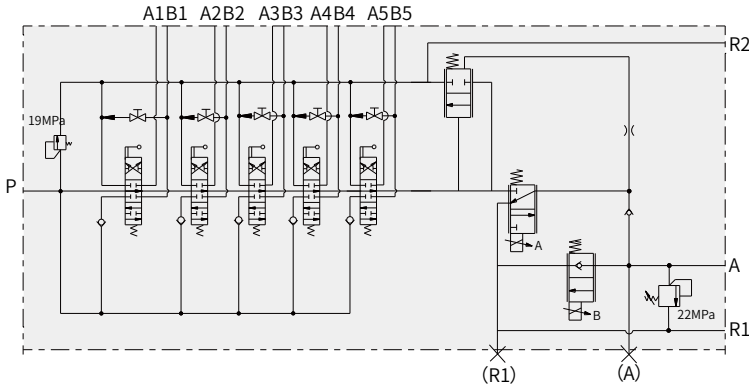

• HVSH16D Mechanical lifting

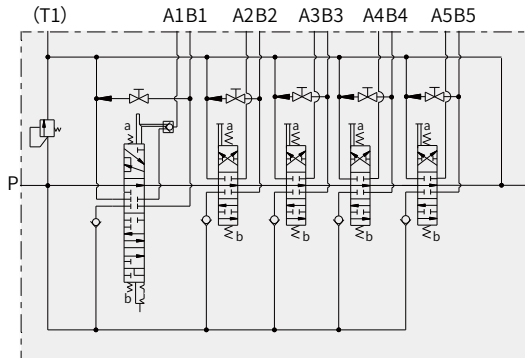

Ordering code

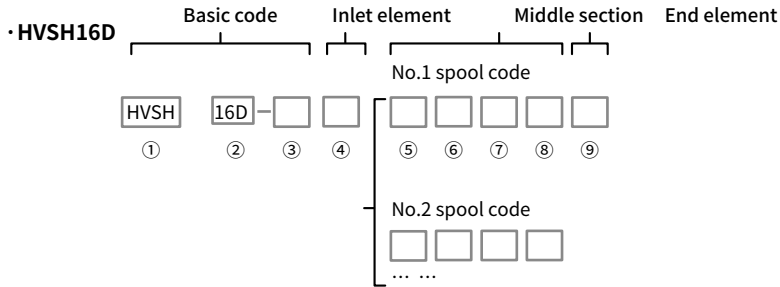

Ordering details: HVSH16D - 03 - P220 - $\left[\begin{matrix} L \\ YP150M \\ Y150SM \end{matrix} \right] - N$

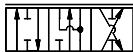
Basic code	① Structure	HVSH	Sandwich plate design
	② Nominal size		16D
	③ Number of directional middle sections		01-07
Inlet element	④ With mechanical holding valve and floating position	P***	With main relief valve, setting pressure, 3- digits, bar
		C	Without main relief valve
Hoist	⑤ Lifting function (Note: need to be next to the first link)	C	CAN bus motor lifting Electrical connectors, Delphi Metri Pack 150.2
		L	Mechanical lifter · Lift positioning + automatic reset function · Floating positioning function.
Ordinary middle directional section	⑥ Spool function	O	O Type 
		Y	Y Type 
	⑦ Relief valve at A side	***	With relief valve, setting pressure, 3- digits, bar
		P	With plug (mutually exclusive with C manipulation type)
	⑧ Relief valve at B side	***	With relief valve, setting pressure, 3- digits, bar
		P	With plug (mutually exclusive with C manipulation type)
⑨ * Operation type	S	Single and double action switching	
	E	CAN bus motor control	
Endlet section	⑩ carry-over function	M	Manual control
		Z	Electro-hydraulic lift taillink
*	Other request		N No carry over
			Further requirement in the clear text

Unit dimensions

· HVSH16D CAN bus motor

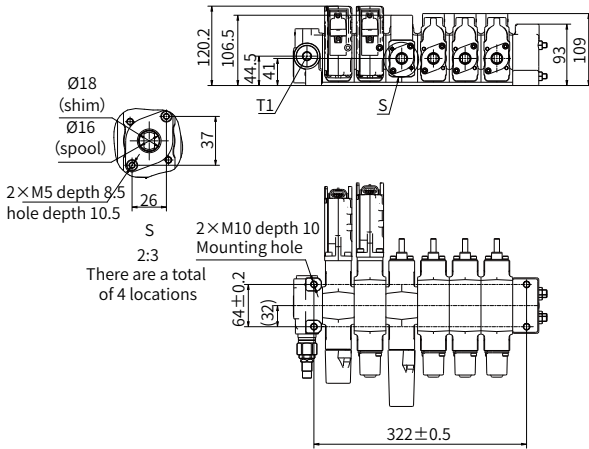
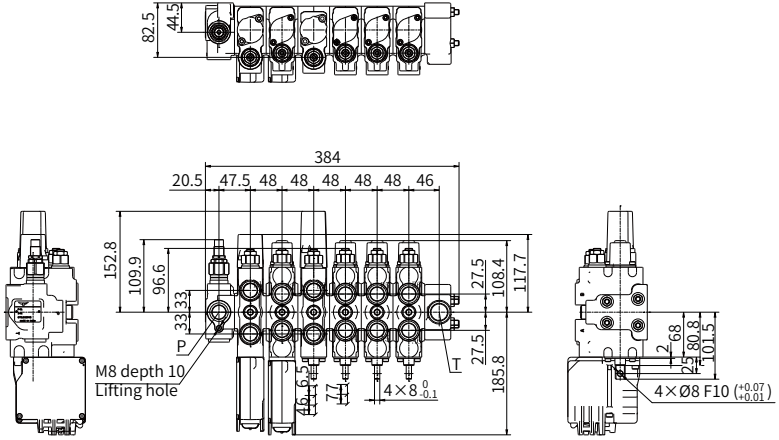

Port connection

• HVSH16D CAN bus motor

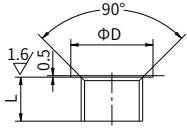
	HVSH16D	Port ISO 9974		Thread	ΦD	L
		P	Inlet port	M22*1.5	28	14
		A / B/ R	Work port	M22*1.5	28	14
		T	Outlet port	M27*2	33	16

Unit dimensions

· HVSH16D Electro-hydraulic lifting

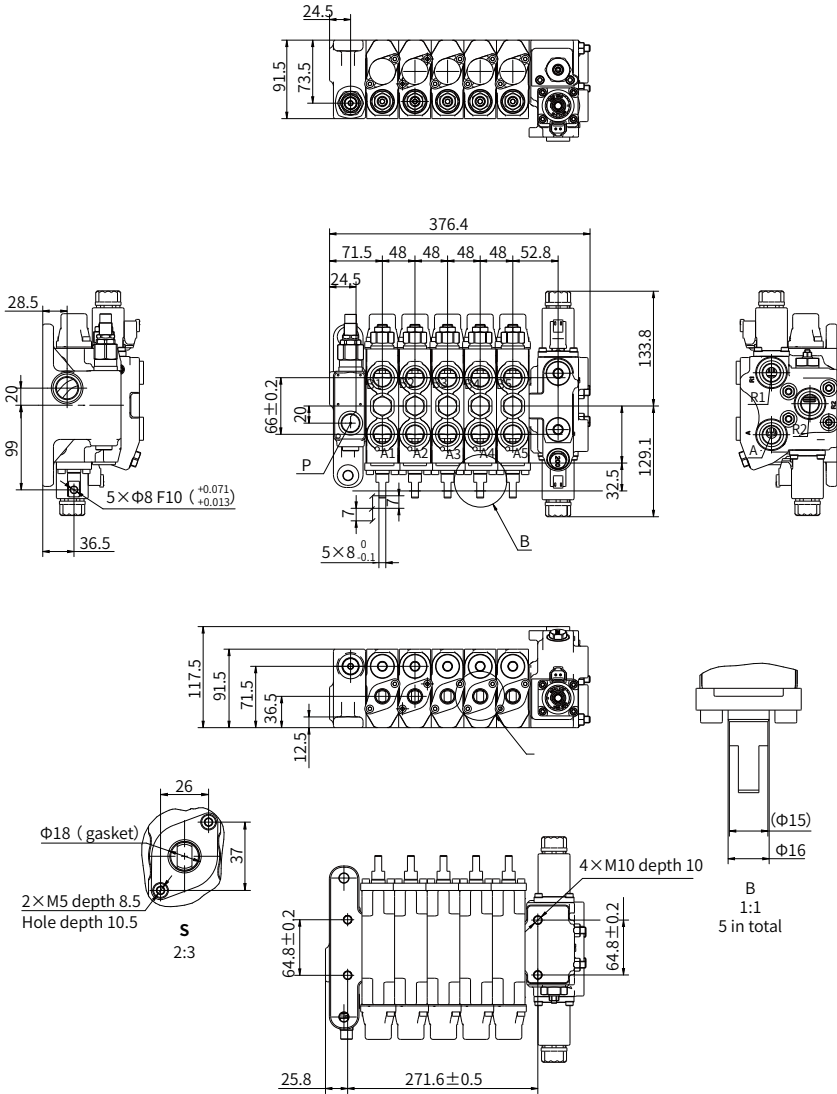

Port connection

• HVSH16D Electro-hydraulic lifting

	HVSH16D	Port ISO 9974		Thread	ΦD	L
		P	Inlet port	M22*1.5	28	14
		A / B/ R	Work port	M22*1.5	28	14
		T	Outlet port	M27*2	33	16

Unit dimensions

· HVSH16D Mechanical lifting

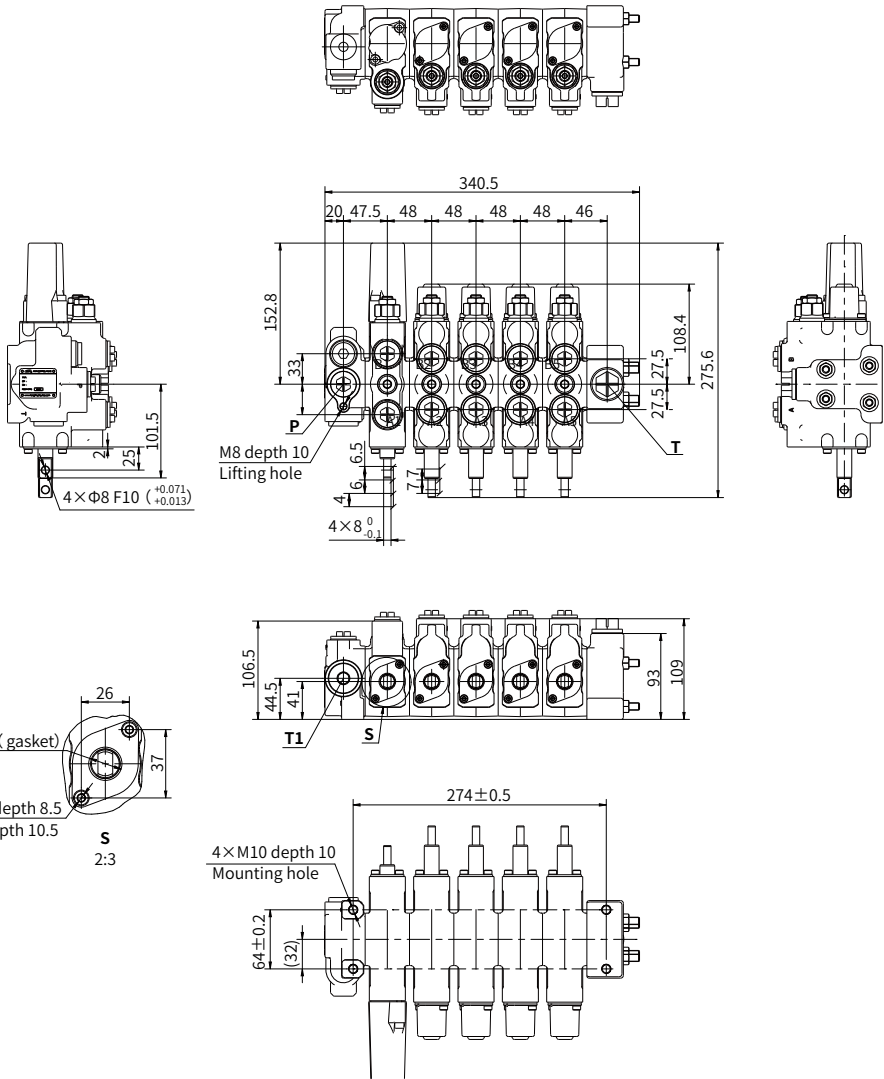

Port connection

• HVSH16D Mechanical lifting

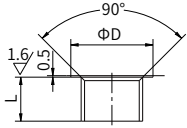
	HVSH16D	Port ISO 9974		Thread	ΦD	L
		P	Inlet port	M22*1.5	28	14
		A / B / R	Work port	M22*1.5	28	14
		T	Outlet port	M27*2	33	16

Section view

· HVSH16B

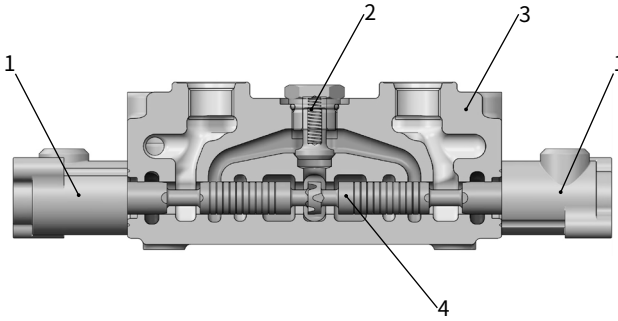

1 Cover

2 Check valve

3 Valve block

4 Spool

Hydraulic diagram

· HVSH16B

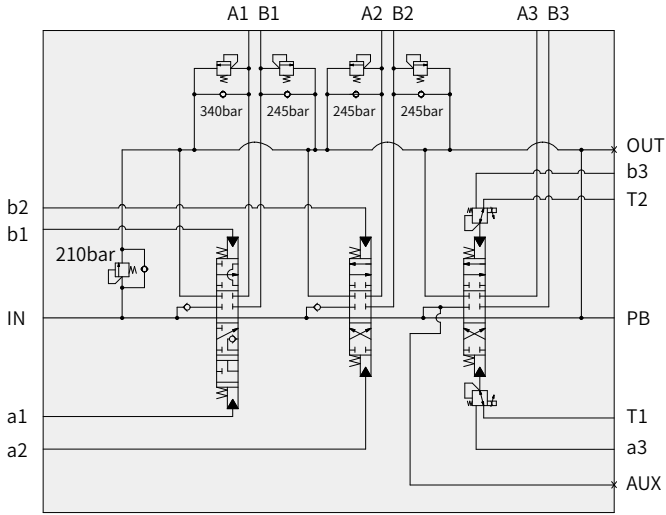

01

Unit dimensions

· HVSH16B

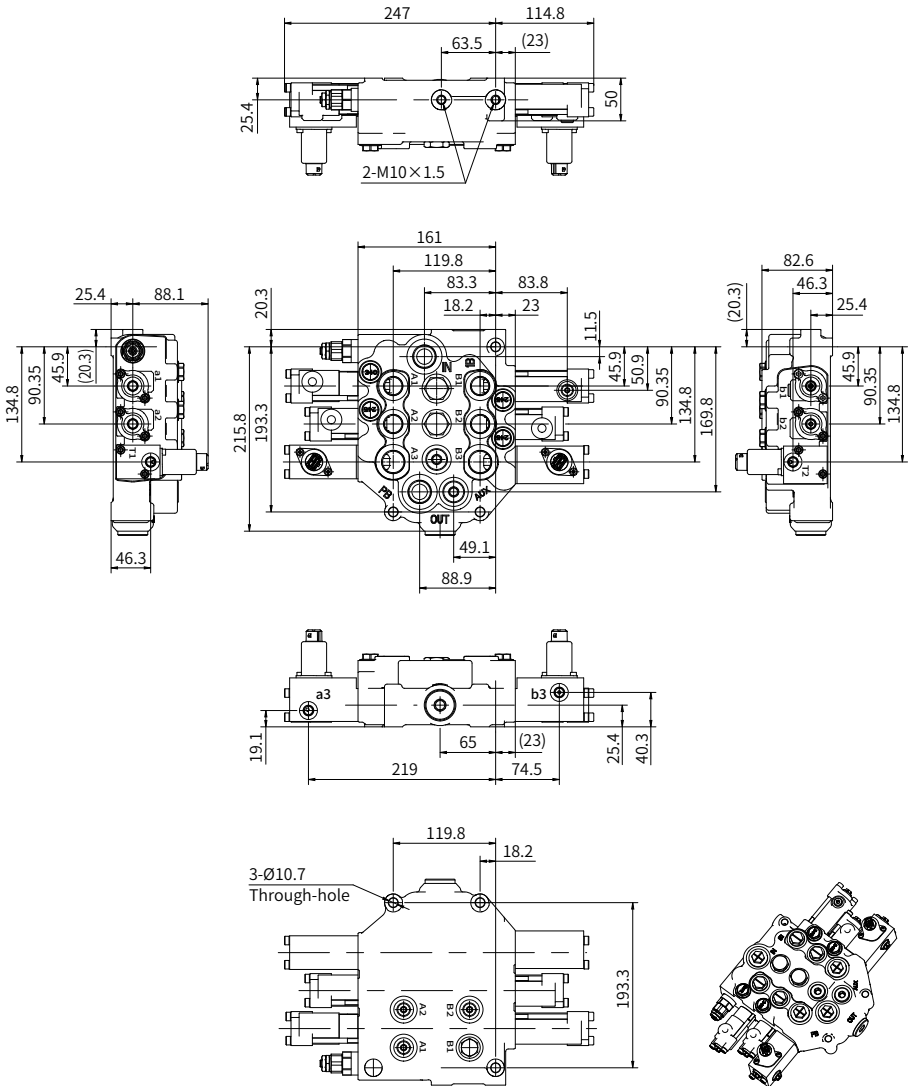

Port connection

·HVSH16B

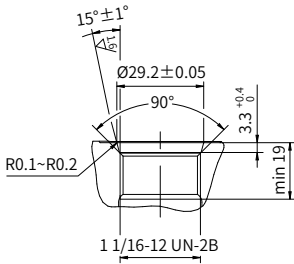

IN, OUT,
PB, A3, B3 Port

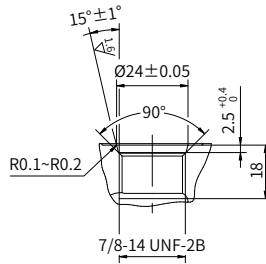

AUX, A1, B1,
A2, B2 Port

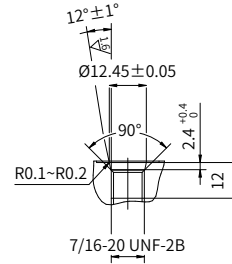

a1, b1, a2, b2,
a3, b3, T1, T2 Port

Section view

· HVSH20 Hydraulic operation

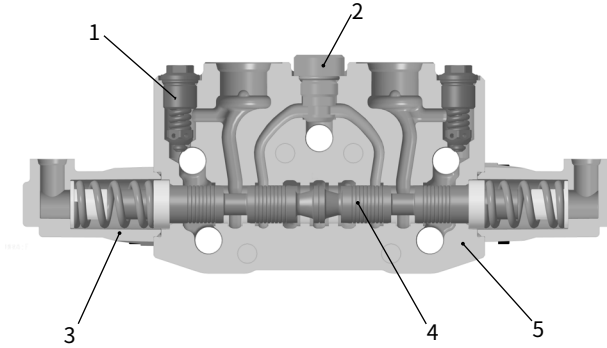

1 Relief valve

2 Check valve

3 Hydraulic control end cap component

4 Spool

5 Valve block

Hydraulic diagram

· HVSH20 Hydraulic operation

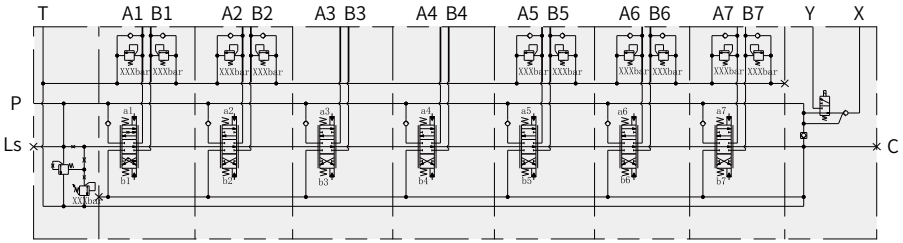

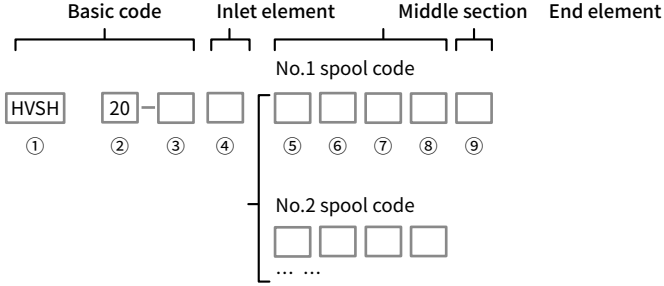

01

Ordering code

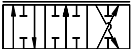

Ordering details: HVSH20 - 02 - P220 - $\left[\begin{array}{l} \text{O150PH} \\ \text{YP150M} \end{array} \right] \text{-K}$

Basic code	① Structure	HVSH	Sandwich plate design
	② Nominal size		20
	③ Number of directional middle sections		01-07
Inlet element	④ Main relief valve	P***	With main relief valve, setting pressure, 3- digits, bar
		C	Without main relief valve
Middle directional section	⑤ Spool function	O	O Type 
		Y	Y Type 
	⑥ Relief valve at A side	***	With relief valve, setting pressure, 3- digits, bar
		P	Without relief valve
	⑦ Relief valve at B side	***	With relief valve, setting pressure, 3- digits, bar
		P	Without relief valve
⑧ * Operation type	H	Hydraulic operation	
Endlet section	⑨ External control solenoid valve	N	Without external control solenoid valve
		K	With external control solenoid valve
*	Other request	Further requirement in the clear text	

Unit dimensions

· HVSH20 Hydraulic operation

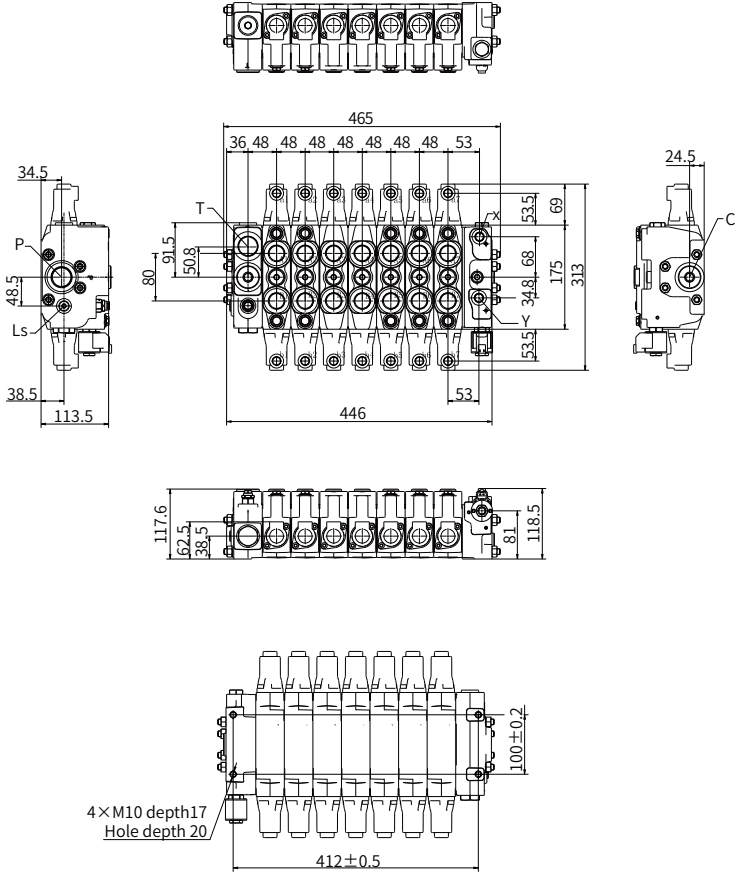

01

Port connection

· HVSH20 Hydraulic operation

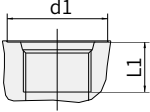
	HVSH20	Port ISO11926		Thread	d1	L1
		P/T/C	Inlet port	1-5/16-12UN	49	19
		A/B	Work port	1-1/16-12UN	41	19
		Pa/Pb	Pilot oil port	9/16-18UNF	25	12.7
		X/Y/LS	Other oil orifice	9/16-18UNF	25	12.7

China

+86 400 101 8889

America

+01 630 995 3674

Germany

+49 (30) 72088-0

Japan

+81 03 6809 1696



© This brochure can be reproduced, edited, reproduced or transmitted electronically without the authorization of Hengli Hydraulic Company. Due to the continuous development of the product, the information in this brochure is not specific to the specific conditions or applicability of the industry, thus, Hengli does not take any responsibility for any incomplete or inaccurate description.