



2.1

HP3G SERIES

Swash-plate Type Axial Piston Variable Displacement Pump

HP3G series variable axial piston pump with swashplate design for hydrostatic drives in closed circuit, high pressure, high speed, high reliability, low noise, can be applied in Aerial work platform.

Applied in medium pressure closed circuit

Size: 46

Rated pressure (bar): 345

Max. pressure (bar): 385



Contents

Technical Data	02-03
Type introduction	04-05
Control mode	
· Electrical displacement control (EDC)	06
Pump principle & installation size	
· HP3G 46	07-10

Features

- Variable axial piston pump of swashplate design for hydrostatic drives in closed circuit.
- The flow is proportional to the drive speed and displacement. The flow increases as the angle of the swashplate is adjusted from zero to its maximum value.
- Flow direction changes smoothly when the swashplate is moved through the neutral position.
- Two pressure-relief valves are provided on the high pressure ports to protect the hydrostatic transmission (pump and motor) from overload.
- The integrated charge pump can provide system replenishing and cooling fluid flow.
- High reliability, long working lifetime
- Compact structure, high power density.

Technical data

Size		46
Displacement (cc/rev)		45.9
Speed	Rated (rpm)	3000
	Max. (rpm)	4100
	Min. (rpm)	500
Pressure	Rated (bar) (relative to Charge pressure)	345
	Max. (bar) (relative to Charge pressure)	385
	Min. low loop pressure(bar) (relative to Charge pump)	10
Charge pressure (relative to Charge pump)	Min. (bar)	6
	Max. (bar)	31
Control Pressure (relative to Charge pump)	Min. (bar) (EDC control)(bar)	21.5
Charge pump displacement (cc/rev)		13.9
Casting pressure	Rated (bar)	1.7
	Max. (bar) (Short-time peak pressure)	5.2
Suction pressure (Absolute pressure)	Rated (bar) Oil viscosity $\leq 30\text{mm}^2/\text{s}$	0.8
	Max. (bar)	6
Oil viscosity (mm ² /s)		10~1000, Best range: 16~36
Oil Temperature (°C)		-20~95
Oil Cleanliness		ISO 4406 20/18/15 or higher
Weight (w/o auxiliary flange) (Kg)		33

Technical data

Permissible input and through-drive torques			
Size			46
Torque at $V_{g,max}$ and $\Delta p = 345 \text{ bar}$ Nm	T		252
Maximum input torque at drive shaft (Nm)			
ANSI B92.1b	7/8 in 13T 16/32DP	$T_{E,max}$	198
	1 in 15T 16/32 DP	$T_{E,max}$	319
	1 1/4 in 14T 12/24 DP	$T_{E,max}$	552
Maximum through-drive torque (Nm)	$T_{D,max}$		198

• Torque distribution

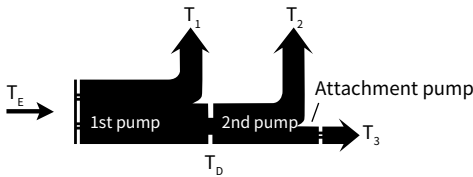

HP3G	1st pump	T_1
	2nd pump	T_2
Attachment pump		T_3
Input torque		$T_E = T_1 + T_2 + T_3$
		$T_E < T_{E,max}$
Through-drive torque		$T_D = T_2 + T_3$
		$T_D < T_{D,max}$

Type introduction

HP3	D	46	E1	M	/	R	N	B1	F4	A2	K2	2	P	S
①	②	③	④	⑤		⑥	⑦	⑧	⑨	⑩	⑪	⑫	⑬	⑭

Product series

①	Variable piston pump of swashplate in closed circuit	HP3
---	--	-----

Nominal pressure

②	nominal pressure 345 bar	G
---	--------------------------	---

Displacement

③	Displacement cc/rev	46
---	---------------------	----

Control mode

④		46	Code
	High current electric proportional displacement control (HC EDC), oil filled, Deutsch DT04-2P, voltage 12V DC, control range: 600mA~1650mA	●	E1
	High current electric proportional displacement control (HC EDC), oil filled, Deutsch DT04-2P, voltage 24V DC, control range: 200mA~500mA	●	E2
	Hydraulic pilot proportional control	●	H2

Displacement Limiters

⑤	Without displacement limiters	Blank
	With displacement limiters	M

Rotation

⑥	Right hand (clockwise)	R
	Left hand (counter-clockwise)	L

Sealing material

⑦	NBR (nitrile rubber) Shaft seal in NBR (nitrile rubber)	N
---	--	---

Mounting flange and input shaft

⑧	Mounting flange	Input shaft	46	Code
	SAE B J744-101-2	ANSI B92.1b 7/8 in 13T 16/32DP	●	B1
		ANSI B92.1b 1 in 15T 16/32 DP	●	B3
		ANSI B92.1b 1 1/4 in 14T 12/24 DP	●	B4

Type introduction

Boost pump and rotary group configuration

⑨	Standard rotary group, without boost pump			K
	Standard rotary group, boost pump integrated	Charge pump displacement (cc/rev)	46	Code
		13.9	●	F4

Through drive option

⑩	Through drive		46	Code
	Without through drive		●	Blank
	Flange	Splined shaft		
	SAE A J744-82-2	ANSI B92.1b 5/8 in 9T 16/32 DP	●	A1
		ANSI B92.1b 3/4 in 11T 16/32 DP	●	A2
	SAE B J744-101-2	ANSI B92.1b 7/8 in 13T 16/32DP	●	B1

High-pressure relief valve

⑪	High-pressure relief valve	Setting range Δp	46	Code
	High pressure relief valve setting (differential pressure: relative to Charge pressure)	250 bar	●	K2
		280 bar	●	K4
		300 bar	●	K5
		320bar	●	K6
		330 bar	●	K7
	345 bar	●	K8	

Remark: Please contact us for configurations or pressures not shown in above form.

Setting pressure of the low pressure relief valve

⑫	21.5 bar	1
	24 bar	2
	26.9 bar	3

Control orifice

⑬	Control orifice of Servo A&B $\phi 0.9\text{mm}$	P
---	--	---

Filtration boost circuit/external boost pressure supply

⑭	Filtration boost circuit/external boost pressure supply	46	Code
	Filtration in the boost pump suction line	●	S
	Filtration in the boost pump pressure line (ports with external filter circuit)	●	D

Remark: ● = Available; ○ = On request

Electrical displacement control (EDC)

The High Current Electrical Displacement Control (HC EDC) consists of a pair of proportional solenoids on each side of a three-position, four-way porting spool. The proportional solenoid applies a force input to the spool, which ports hydraulic pressure to either side of a double acting servo piston. Differential pressure across the servo piston rotates the swashplate, changing the pump's displacement from full displacement in one direction to full displacement in the opposite direction.

A serviceable 125 μm screen is located in the supply line immediately before the control porting spool.

Features:

- Precision parts provide repeatable accurate displacement settings with a given input signal.
- Both ends of the double acting servo piston are drained to case when input signal current is not present. The servo piston is coupled to a spring centering mechanism.

Benefits:

- Simple, low-cost design.
- Pump will return to neutral after prime mover shuts down.
- Pump will return to neutral if external electrical input signal fails or if there is a loss of charge pressure

• Pump displacement — control current

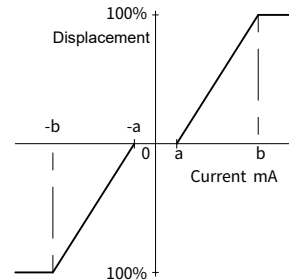

• EDC Response time

Orifice diameter* mm [in]	Average response time [seconds]	
	Acceleration	Deceleration
1.2 [0.046]	2.0	1.6
None	0.9	1.0

*Contact Hengli for special orifice combinations.

HP3G46 Pump principle

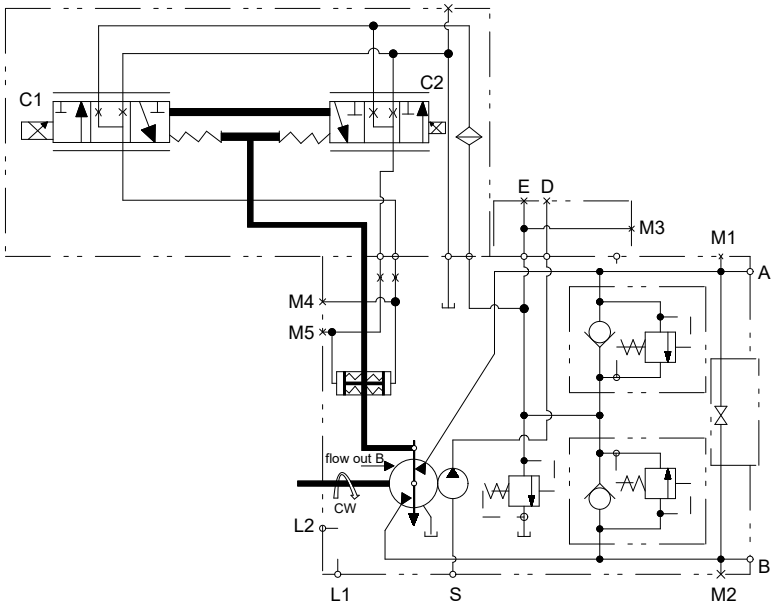

Input shaft rotation	CW		CCW	
Energized coil	C2	C1	C2	C1
Oil port A	Out	In	In	Out
Oil port B	In	Out	Out	In
Servo pressure acting oil port	M4	M5	M4	M5

Connector:

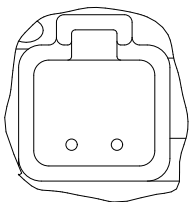

Deutsch DT04-2P
 Voltage: 12V/24V
 V View

Refer to pump installation drawing for port locations.

Installation size

HP3G46 installation size

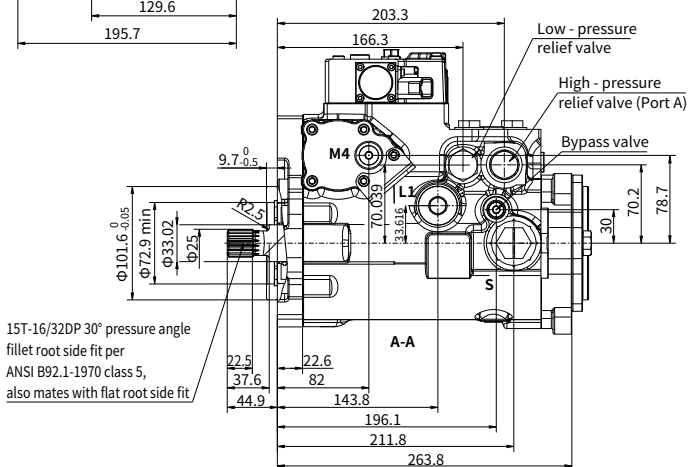
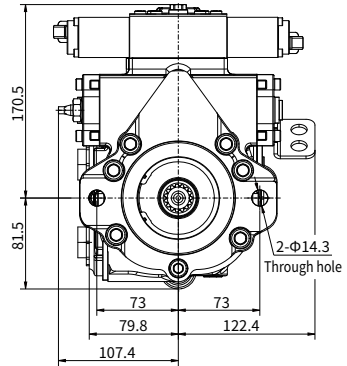
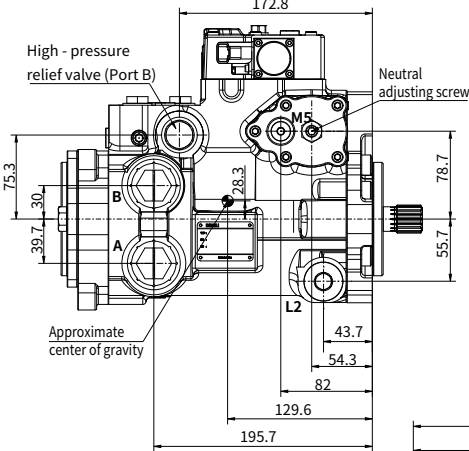
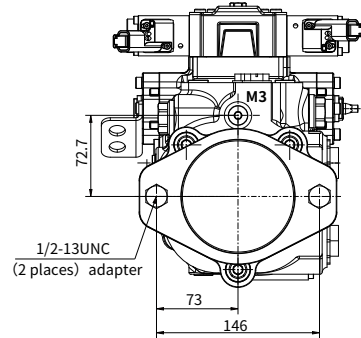
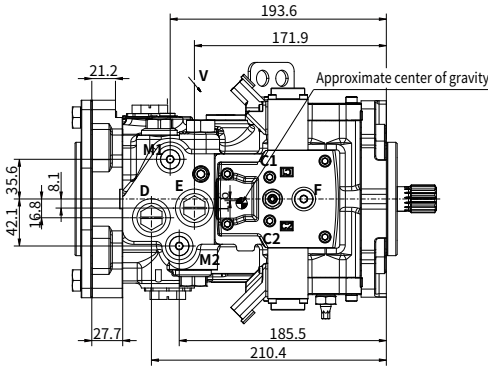

Installation size

· HP3G46 Port details

	Port Name	Port Size and Description	Tightening Torque(N.m)	Maximum pressure (bar)
S	Suction port	SAE J1926/1 (1 5/16-12UN-2B)	134	6
A, B	Working port	SAE J1926/1 (1 5/16-12UN-2B)	134	385
L1, L2	Drain port	SAE J1926/1 (1 1/16-12UN-2B)	101	2
M1, M2	Port "A" and "B" gage port	SAE J1926/1 (9/16-18UNF-2B)	25	385
M3	Gauge port of charge pump	SAE J1926/1(9/16-18UNF-2B)	25	27
M4, M5	Servo gage port	SAE J1926/1 (9/16-18UNF-2B)	25	27
D	Charge filtration port D (To remote filter ISO 11926-1 7/8-14 Charge filtration port D charge gauge port for remote filtration with charge pump option)	SAE J1926/1 (7/8-14UNF-2B)	73	27
E	Charge filtration port E (From remote filter charge gauge port for remote filtration with or w/o charge pump option)	SAE J1926/1 (7/8-14UNF-2B)	73	27
F	Air bleed port	SAE J1926/1(7/16-20UNF-2B)	15	2

Installation size

HP3G Mounting Flange

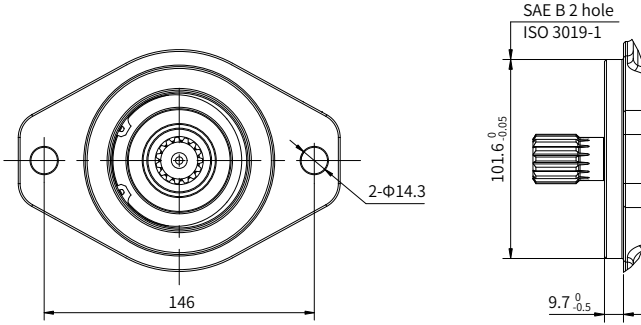

02

HP3G Input Shaft type

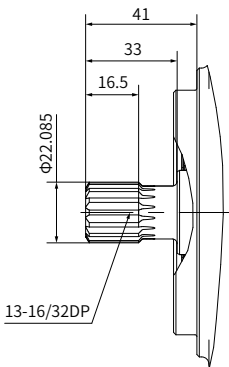

"B1" type spline shaft

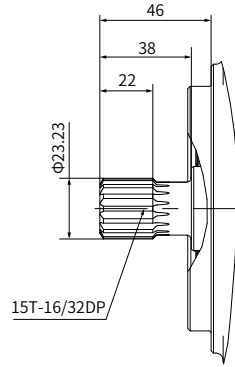

"B3" type spline shaft

China

+86 400 101 8889

America

+01 630 995 3674

Germany

+49 (30) 72088-0

Japan

+81 03 6809 1696



© This brochure can be reproduced, edited, reproduced or transmitted electronically without the authorization of Hengli Hydraulic Company. Due to the continuous development of the product, the information in this brochure is not specific to the specific conditions or applicability of the industry, thus, Hengli does not take any responsibility for any incomplete or inaccurate description.