



7.1

FBRC TYPE

Dual Counterbalance Valve

Rated pressure (bar / psi)	350 / 5075
Maximum flow (L/min / gpm)	60 / 15

Features

- Small size, stable and reliable
- Stable crack pressure, and less impact when crack and reseal
- Accurate flow control
- Enhance the safety of the system

Contents

Description	02
Operation	02
Ordering code	02
Materials	02
Technical data	03
Performance	03
Dimensions	04

Symbol

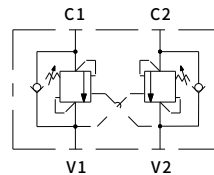

Description

Hydraulic counterbalance valve, mainly used to balance the pressure in hydraulic systems and control the flow rate of hydraulic circuits.

Operation

Static and dynamic control is achieved by adjusting the flow of port C1 and port C2. The valve consists of two parts, each consisting of a check valve and a relief valve, which provide pilot assistance through reverse pipeline pressure: the check valve allows flow freely into the actuator, and then maintains the load to prevent reverse movement; when applying pilot pressure on the crossover pipeline, the pressure setting of the relief valve decreases proportionally according to the set ratio until it opens and allows controlled reverse flow. Add the back pressure at V1 or V2 to the pressure settings of all functions. To make the assembly safer and more compact, the C2 oil port can be directly installed on the actuator through a sealing gasket.

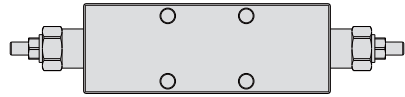

Ordering Code

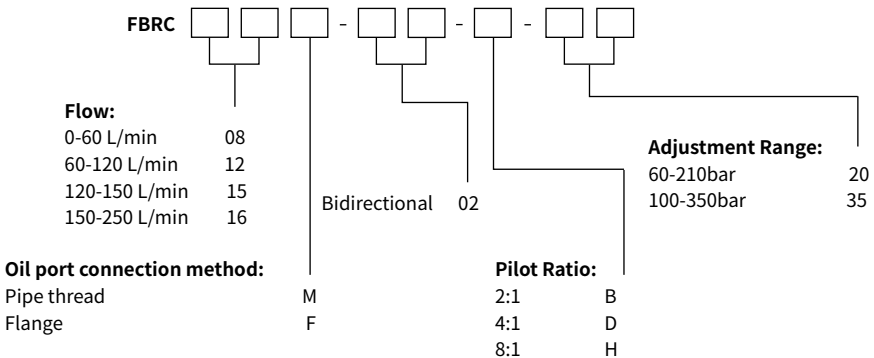

Materials

Cartridge:

Steel with hardened work surfaces. Zinc-plated exposed surfaces; Buna Nseal.

Standard Ported Body:

Anodized high-strength aluminum alloy; Ductile iron and steel bodies available; Dimensions may differ, consult factory.

Technical Data

Rated pressure	350 bar (5000 psi)
Maximum flow	60 L/min (15 gpm)
Adjustment range	100-350 bar
Pilot ratio	2:1, 4:1, 8:1
Fluid	Mineral-based or synthetics with lubricating properties
Viscosity range	7.4 to 420 mm ² /s
Temperature range	-40 to 100 °C (Buna N seals)
Degree of fluid contamination	The minimum pollution level is ISO4406 level 20/18/14, and level 17/15/13 is recommended to prolong the service life

Performance (Cartridge Only)

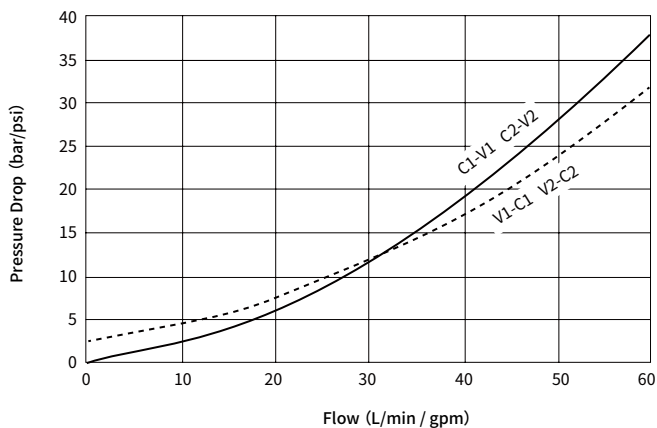

Dimensions

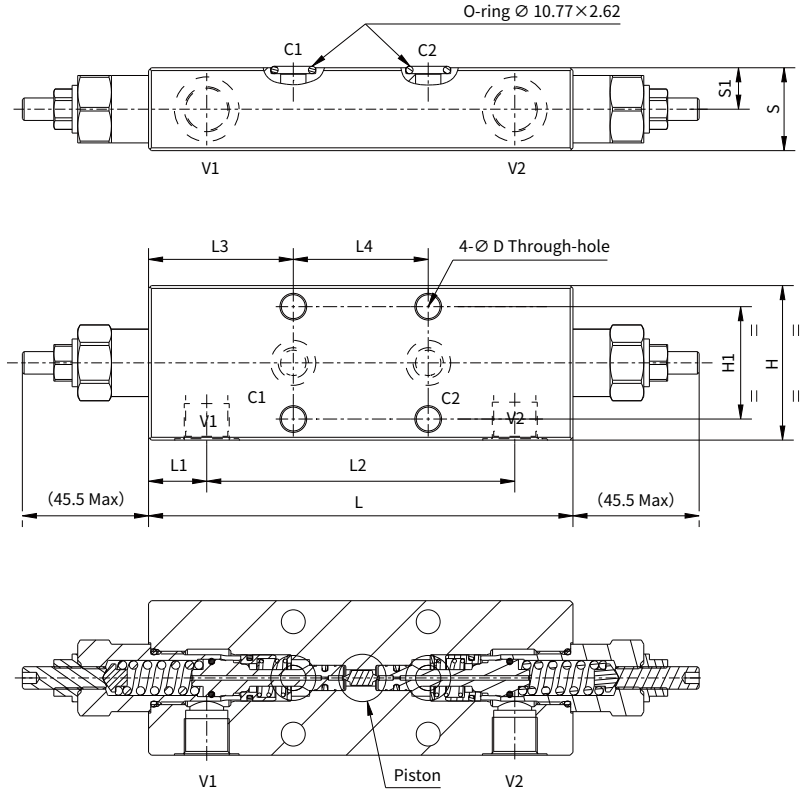

Size / mm								Port dimension/ ISO 1179		Technical data			Material
L×H×S	L1	L2	L3	L4	H1	S1	D	V1、V2	C1、C2	Max. flow (L/min)	Pilot ratio	Pressure range (bar)	
151×55×29.5	20.7	109.6	51.5	48	40	14.75	8.5	G3/8	$\varnothing 9$	60	4:1	100-350	Alumi- nium/ Steel
151×65×34.5	20.7	109.6	51.5	48	40	17.25	8.5	G1/2			4:1		
160×55×30	21.5	117	56	48	40	15	8.5	G3/8			2:1 4:1 8:1		
138×50×25	23	92	50	38	28	12.5	6.5	G1/4	$\varnothing 6$	30	4:1		

Note: Sizes, flow, lead ratios, etc. can be customized according to customer needs.