



1.6.1

EHV SERIES

FLOW SHARING VALVE

EHV:

Nominal size:	06
Rated pressure(bar):	310
Rated flow(L/min):	60

Benefits:

- High efficiency
- Less volume, lighter weight
- Precise controllability
- Low pressure drop, less fuel consumption
- Quick response

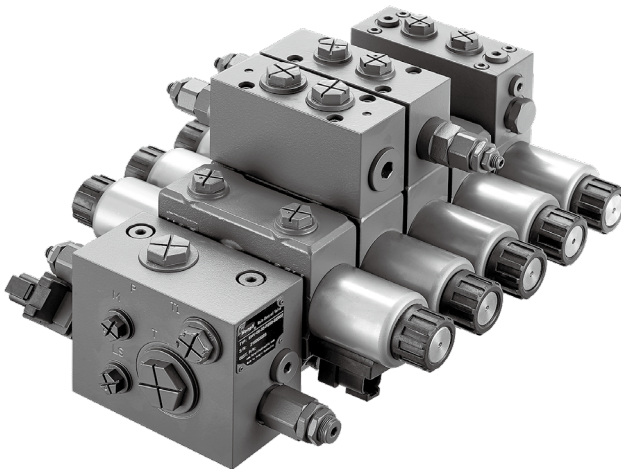

Contents

	Page
Features	03
Section view	04
Technical data	05
Ordering code	06-07
Hydraulic diagram	08
Inlet section assembly	
· Inlet section assembly	09
· Inlet section assembly-with LS solenoid operated unloading valve	10
Middle section assembly	
· Middle section assembly	11
· Middle section assembly-With relief valve	12
· Middle section assembly-With hydraulic operated check valve	13
Endlet section assembly	14
Unit dimensions	15

Features

1. System:

Flow pressure independent flow distribution

Open center, for fixed displacement pump

Closed center, for load-sensing variable displacement pump

- Priority function
- Less control pressure, $\Delta P=15\text{bar}$
- Each movements priorities adjustable
- Electrical switch and electrical proportional control

2. Structure

- Sandwich plate of design
- Max. 10 middle section

3. Pressure

- Primary and secondary pressure relief valve
- LS pressure relief valve

4.Flow

- Load pressure compensated
- High repeatability accuracy
- Low hysteresis
- Quick response

5. Applications



Aerial work platform



Agricultural machinery



Cranes



Telescopic handler



Wet spraying machine
(concrete machinery)

Section view

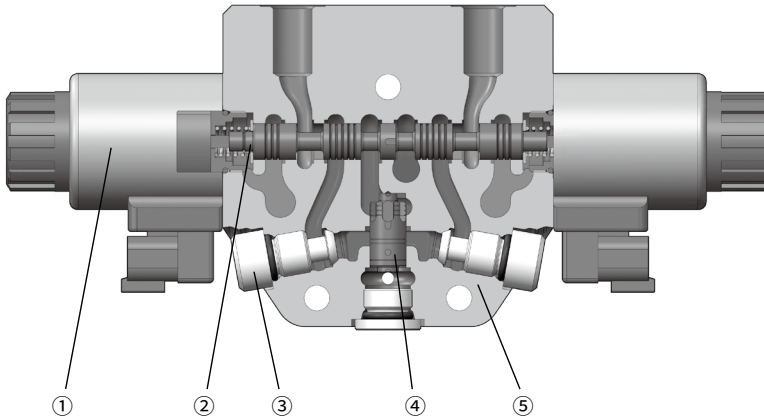

- | | |
|---------------------|----------------------|
| 1. Solenoid | 2. Main spool |
| 3. Load check valve | 4. Compensator valve |
| 5. Valve block | |

Technical data

General

Structure	Stackable, load sensing, post pressure compensated		
Type of connection	ISO BSP thread, metric thread		
Mass (kg)	Inlet element		4.27/5.3
	Middle section	General	3.50
		With relief valve	5.58
		With hydraulic operated check valve	4.86
End element		0.27	

Hydraulic

Nominal size		06
Rated flow	Q (L/min)	60
	P /LS (bar)	310
Rated operating pressure at port	A/B (bar)	310

Electric

<p>Electrical on/off:</p> <ul style="list-style-type: none"> · Connection: Deutsch DT04-2P · Protection class: IP69k · Supply voltage: 12 or 24VDC 	<p>Electrical proportional:</p> <ul style="list-style-type: none"> · Dither frequency required: 120Hz · Hysteresis: Less than 3% · Connection: Deutsch DT04-2P · Protection class: IP69k · Control current @12VDC: 0~1800mA, @24VDC: 0~1200mA
---	--

Using environment

Hydraulic fluid	Mineral oil (HL, HLP) according to DIN 51524. Other hydraulic fluids, such as HEES (Synthetic Ester) according to VDMA 24568.
Hydraulic fluid temperature range(°C)	-20 ~ +80
Viscosity range ν (mm ² /s)	10 ~ 380
Maximum permissible degree of contamination of the pressure fluid cleanliness class to ISO 4406 (C)	Class 20/18/15, we therefore recommend a filter with a minimum retention rate of $\beta_{10} \geq 70$

(For applications outside above mentioned parameters, please consult our sales dept.)

Ordering code

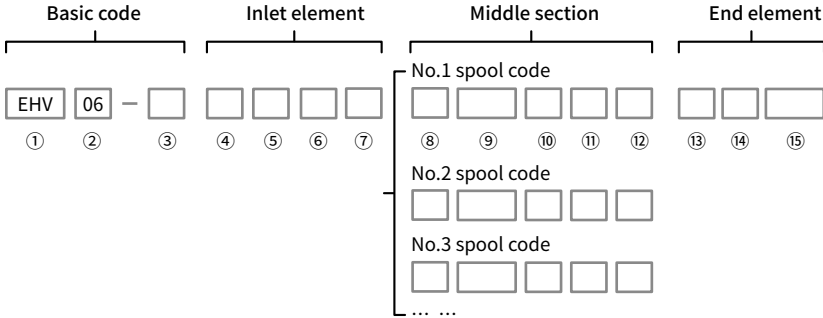

Basic code	① Structure	EHV	Stackable, load sensing, post pressure compensated
	② Nominal size	06	
	③ Number of blocks	..	01~10
Inlet element	④ Circuit types	C	Closed center, for variable piston pump system
		O	Open center, for fixed displacement pump system
	⑤ Main relief valve	Q	Without main pressure relief valve
		P...	With main pressure relief valve, (pressure in bar, 3-digits)
	⑥ LS relief valve	Q	Inlet element without LS pressure relief valve (LS relief valve plug)
	S...	Inlet element with LS pressure relief valve (pressure in bar, 3-digits)	
⑦ LS unload		LZ	Without LS unload function
		LA	With LS unload function: normal open
		LB	With LS unload function: normal close
Middle section	⑧ Spool symbol	E1	=E1
		E2	=E2
		E3	=E3
		Q1	=Q1
		Q2	=Q2

Ordering code

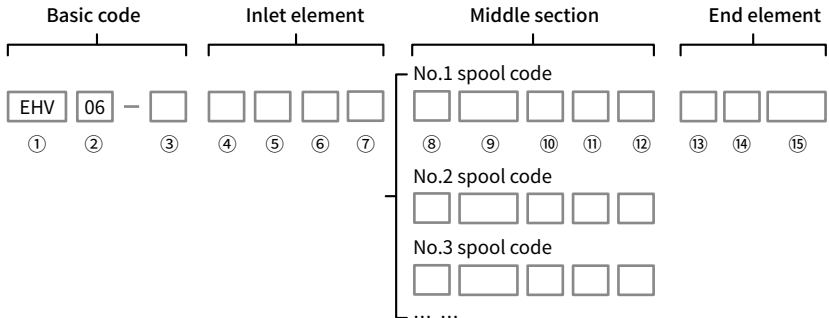

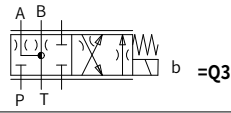
Middle section	⑧ Spool symbol	Q3		
	⑨ A/B flow	..—..	Flow in l/min, 2-digits, e.g. 50-50	
	⑩ Operator type	W21	Electrical proportional control, 24V, (optional with manual override button)	
		W23	Electrical proportional control, 12V (optional with manual override button)	
		W41	Electrical switch control, 24V (optional with manual override button)	
		W43	Electrical switch control, 12V (optional with manual override button)	
	⑪ A/B port relief valve	Blank	Without port relief valve	
		QQ	Plug, without relief valve (port relief valve can be added)	
		G...G...	G200G200, pressure in bar, pressure details of port relief valve in 3 digits	
	⑫ AB hydraulic operated check valve	OO	Without hydraulic operated check valve	
AB		The AB port has a hydraulic operated check valve		
AO		Only A port has a hydraulic operated check valve		
OB		Only B port has a hydraulic operated check valve		
End element	⑬ Additional P port	Blank	Without additional P port	
		P	With additional P port	
Others	⑭ Sealing type	V	FKM	
		N	NBR	
	⑮ Design code	001		
*	Other request	Further requirement in the clear text		

Hydraulic diagram

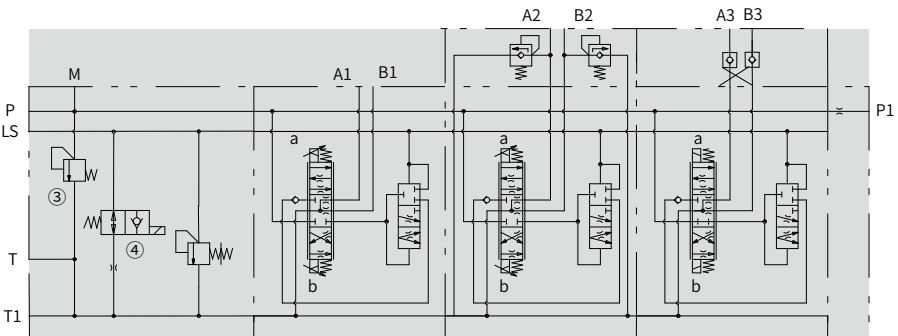
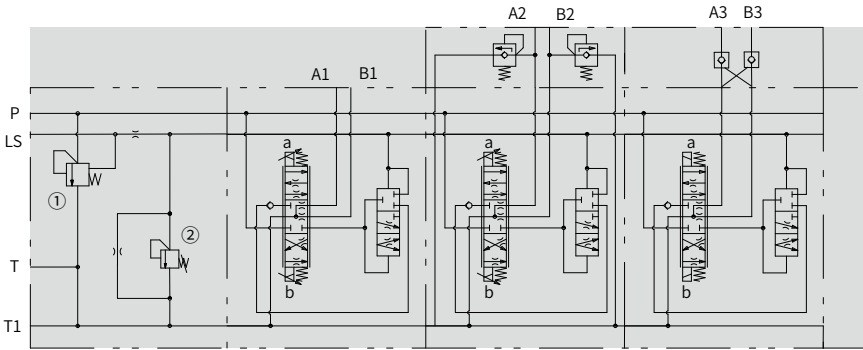

- ① Three-way flow unloading valve (suitable for quantitative pump system)
- ② LS relief valve
- ③ Main pressure relief valve (suitable for variable pump system)
- ④ LS unload valve

Inlet section assembly

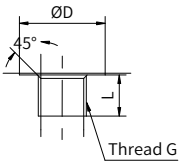
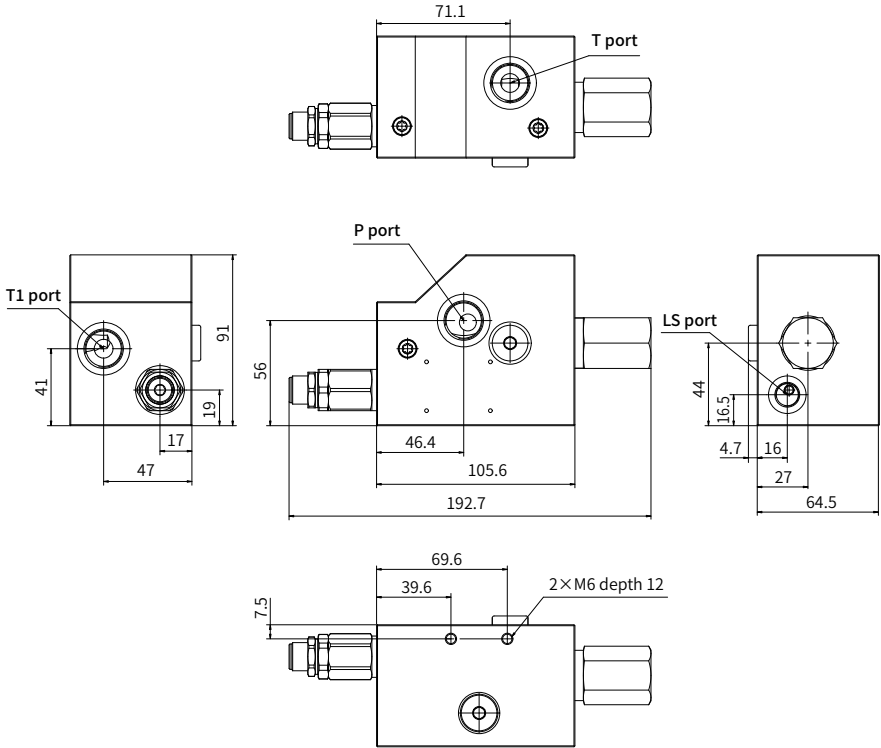

Port dimension		Thread dimensions	
P port:	G1/2	G1/2:	Ø D 28 L 15
T, T1 port:	G1/2	G1/4:	Ø D 20 L 12.5
LS port:	G1/4		

01

Inlet section assembly-With LS solenoid operated unloading valve

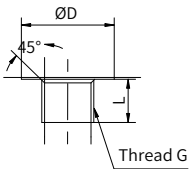
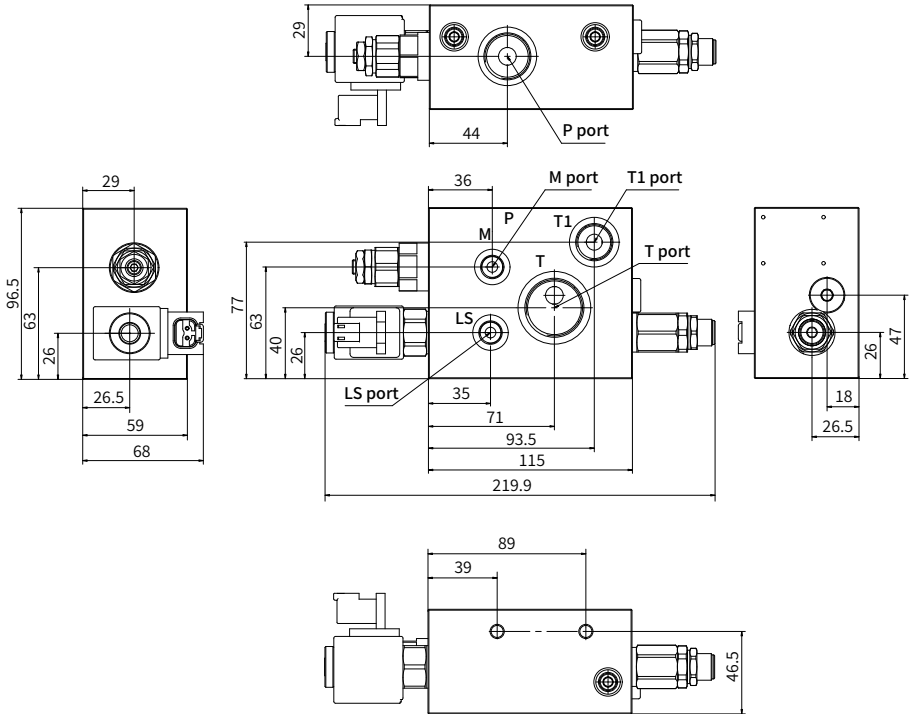

Port dimension

P port: G3/4
 T port: G1
 T1 port: G1/2
 LS port: G1/4
 M port: G1/4

Thread dimensions

G3/4: Ø D 33 L 16.5
 G1: Ø D 41 L 19
 G1/2: Ø D 28 L 15
 G1/4: Ø D 20 L 12.5

Middle section assembly

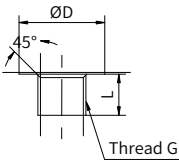
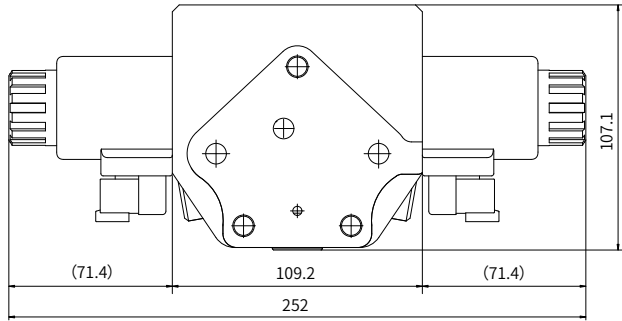
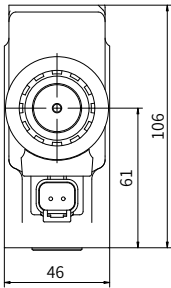
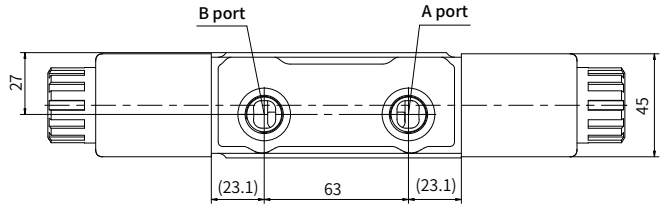

Port dimension

A/B port: G3/8
or G1/2

Thread dimensions

G3/8: $\varnothing D$ 23 L 12.5
G1/4: $\varnothing D$ 20 L 12.5

Middle section assembly-With relief valve

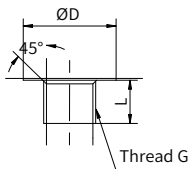
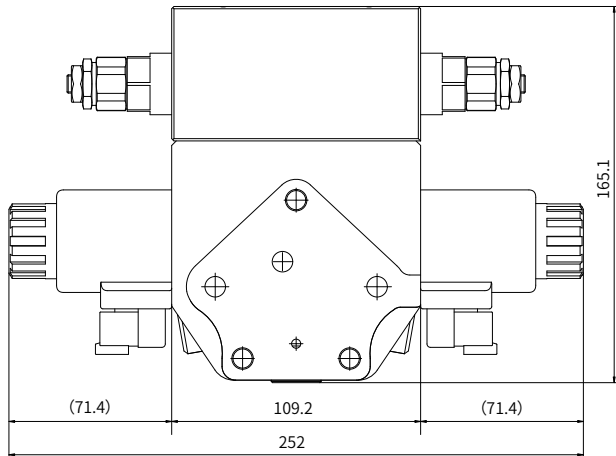
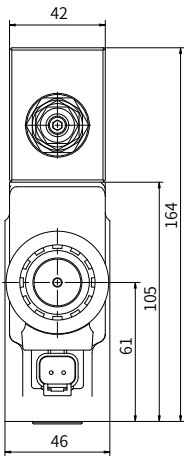
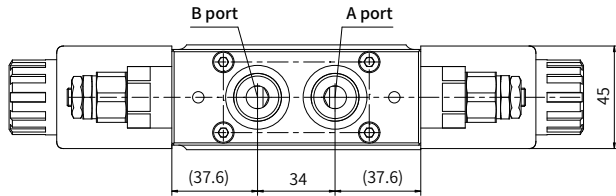

Port dimension

A/B port: G3/8
or G1/2

Thread dimensions

G3/8: $\varnothing D$ 23 L 12.5
G1/2: $\varnothing D$ 28 L 15

Middle section assembly-With hydraulic operated check valve

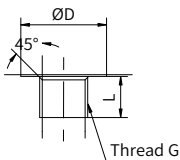
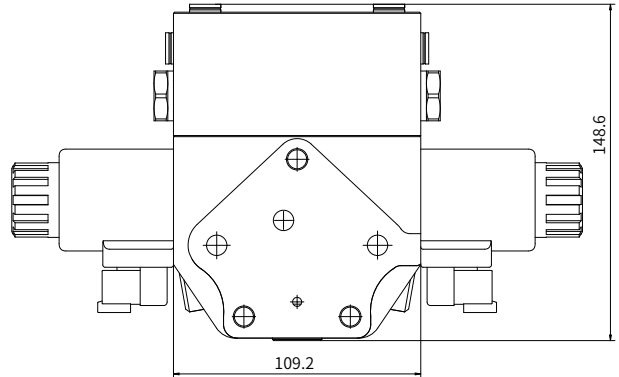
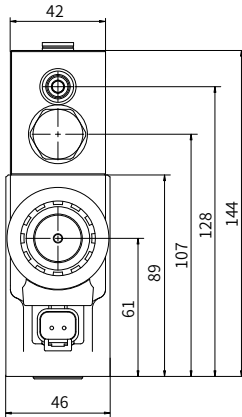
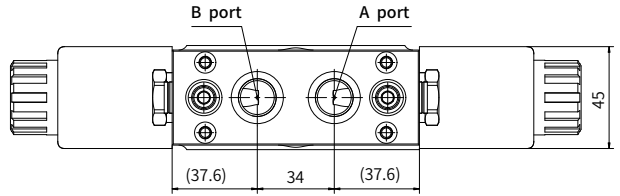

Port dimension	Thread dimensions
A/B port: G3/8	G3/8: Ø D 23 L 12.5

01

Endlet section assembly

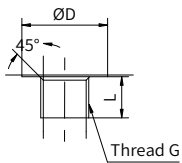
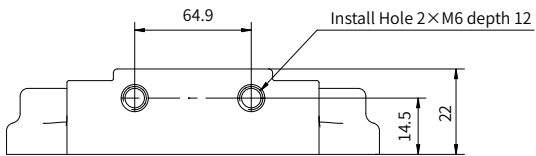
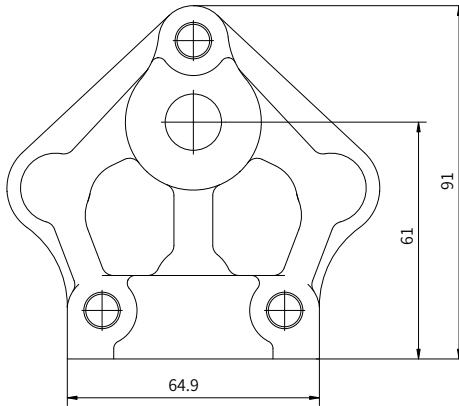

Port dimension

P port: G3/8

Thread dimensions

G3/8: $\text{Ø D } 23$ L 12.5

Unit dimensions

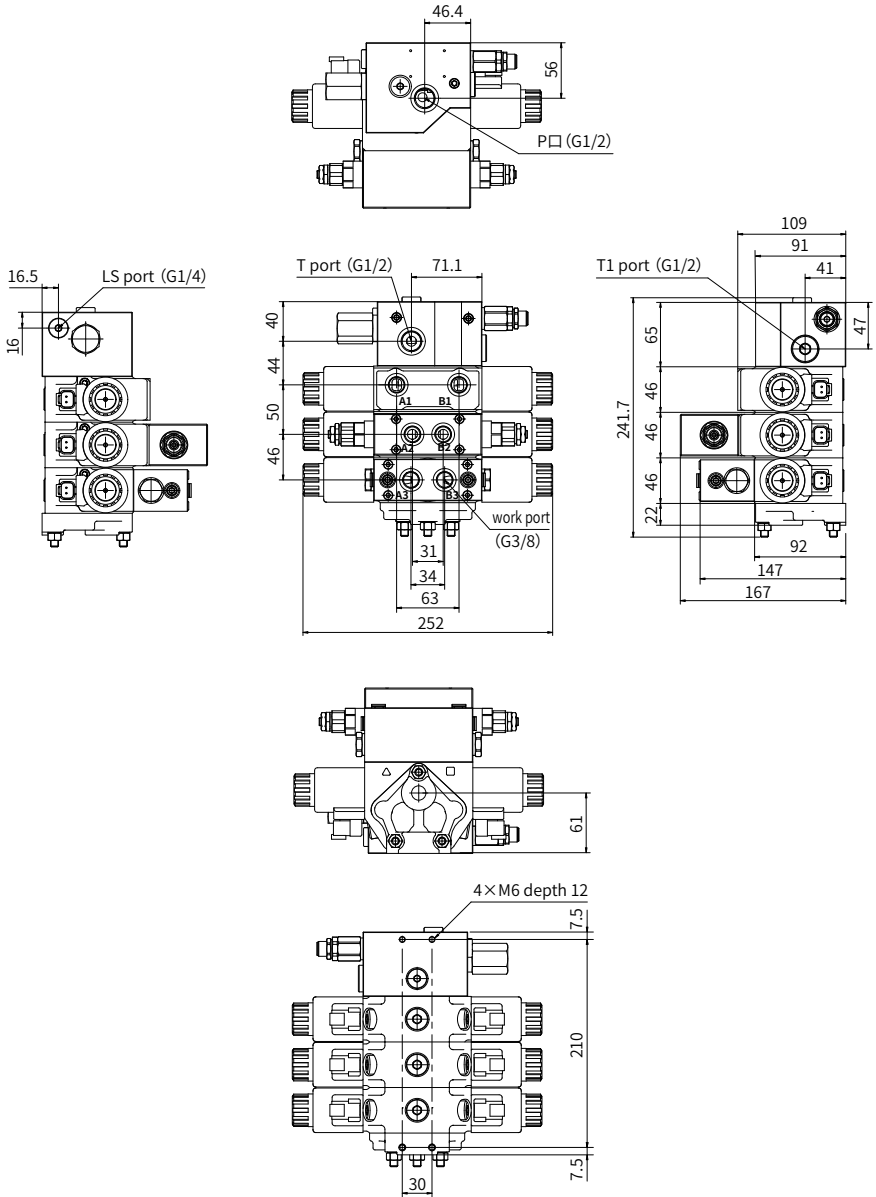

01

China

+86 400 101 8889

America

+01 630 995 3674

Germany

+49 (30) 72088-0

Japan

+81 03 6809 1696



© This brochure can be reproduced, edited, reproduced or transmitted electronically without the authorization of Hengli Hydraulic Company. Due to the continuous development of the product, the information in this brochure is not specific to the specific conditions or applicability of the industry, thus, Hengli does not take any responsibility for any incomplete or inaccurate description.



1.6.2

EHV SERIES

FLOW SHARING VALVE

EHV:

Nominal size	09P	09S	18
Rated pressure(bar) pump side/actuator side	280/340	280/320	320/340
Rated flow(L/min)	90	90	180

Benefits:

- High efficiency
- Less volume,
lighter weight
- Precise controllability
- Low pressure drop,
less fuel consumption
- Comfort and coordination

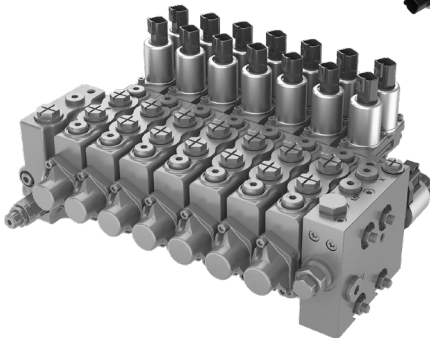

EHV 09P

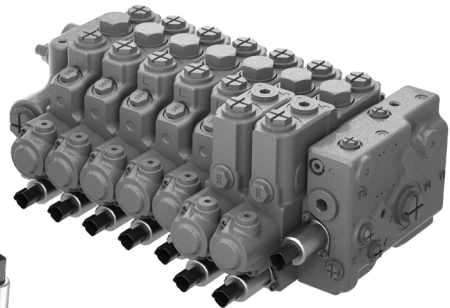

EHV 18

Contents

	Page
Features	03
Section view	04
Technical data	05
Ordering code	06-07
EHV 09P/09S Hydraulic diagram and Unit dimensions	08-09
EHV 09P Inlet section assembly	10
EHV 09P Middle section assembly	11
EHV 09S Middle section assembly	12-13
EHV 09P/09S Unit dimensions	14
EHV 18 Hydraulic diagram and Unit dimensions	15-16
EHV 18 Inlet section assembly	17
EHV 18 Middle section assembly	18-19
EHV 18 Unit dimensions	20-21

Features

1. System:

Load pressure independent flow distribution

- Anti-drop valve
- Regeneration capability
- Low control pressure, $\Delta P=15\text{bar}$
- Adjustable priority order of each movement
- Hydraulic pilot control, Electrical switch and electrical proportional control

2. Structure:

- Sandwich plate of design

3. Pressure:

- LS relief valve
- Secondary pressure relief valve

4. Flow:

- Load pressure compensated
- High repeatability accuracy
- Low hysteresis

5. Applications:



Excavators



Telescopic handler



Aerial work platform



Drilling rigs

Section view

· EHV 09P/09S

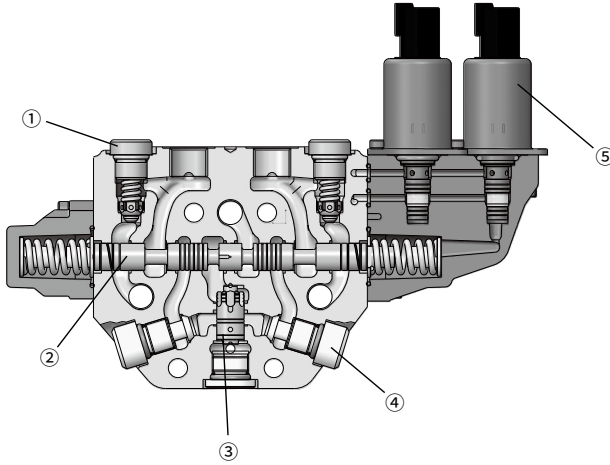

· EHV 18

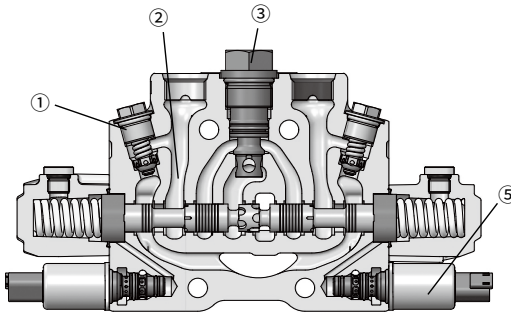

1. Relief valve

2. Spool

3. Compensator valve

4. Load check valve

5. Solenoid Valve

Technical data

General

Structure	Stackable, proportional, load sensing, pre-compensated				
			09P	09S	18
Connection type				ISO1179-1	JISB2351-1
Mass (kg)	Inlet element		3.4		9.2
	Middle section	Hydraulic operation	2.7	3.4	7.5
		E-H operation	3.3	2.9	7.8
	End element		3.2		5.7

Hydraulic

Nominal Size		09P	09S	18
Rated flow	Q (L/min)	90 ($\Delta P=15\text{bar}$)	90 ($\Delta P=15\text{bar}$)	180 ($\Delta P=15\text{bar}$)
Max. operating pressure at port	P /LS (bar)	280	280	320
	A/B (bar)	340	320	340
	T (bar)	30		
	TS (bar)	Less than 2		
Pilot pressure	a/b (bar)	Less than 35		
	X (bar)	30		

Electric

Electrical on/off: · Connection: Deutsch DT04-2P · Protection class: IP69k · Supply voltage: 12 or 24VDC	Electrical proportional: · Dither frequency required: 100-200Hz · Connection: Deutsch DT04-2P/AMP Junior-Timer · Protection class: IP69k · Control current @12VDC: 0~1500mA; @24VDC: 0~750mA
---	--

Using environment

Hydraulic fluid	Mineral oil (HL, HLP) according to DIN 51524. Other hydraulic fluids, such as HEES (Synthetic Ester) according to VDMA 24568.
Hydraulic fluid temperature range(°C)	-20 to +90
Viscosity range ν (mm ² /s)	10 to 380
Maximum permissible degree of contamination of the pressure fluid cleanliness class to ISO 4406 (C)	Class 20/18/15, we therefore recommend a filter with a minimum retention rate of $\beta_{10} \geq 75$

(For applications outside above mentioned parameters, please consult our sales dept.)

Ordering code

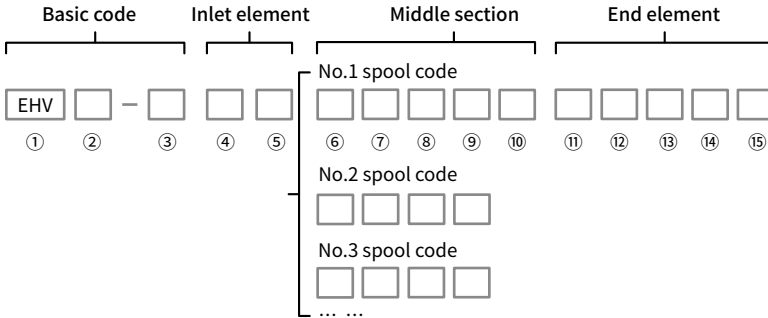

Basic code	① Structure	EHV	Stackable, load sensing, post pressure compensated		
	② Nominal size		09P	09S	18
	③ Number of blocks	..	01~10		
Inlet element	④ Circuit types	C	Closed center, for variable piston pump system		
		O	Open center, for fixed displacement pump system		
	⑤ LS relief valve	Q	Without LS pressure relief valve		
		S...	with LS pressure relief valve (pressure in bar, 3-digits)		
Middle section	⑥ Spool symbol	E1	=E1		
		E2	=E2		
		E3	=E3		
		Q1	=Q1		
		Q2	=Q2		

Ordering code

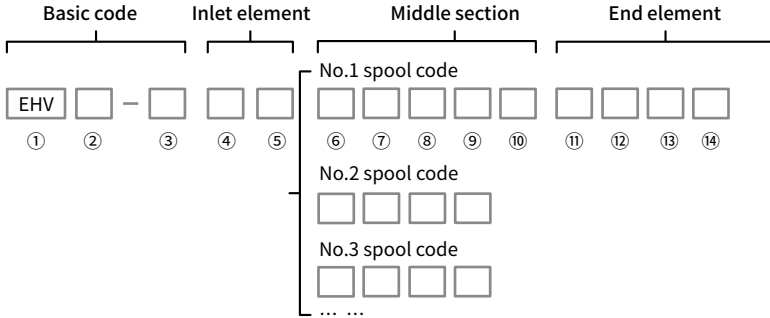

Middle section	⑥ Spool symbol	Q3			
	⑦ A/B flow	Flow in l/min, 2-digits, e.g. 50-50		
	⑧ Pipe Burst Safety Valve	Q	Without anti-drift valve		
		L	With anti-drift valve		
	⑨ Operator type	H	Hydraulic		
		W21	Electrical proportional control, 24V		
W23		Electrical proportional control, 12V			
W41		Electrical switch control, 24V			
⑩ A/B port relief valve	W43	Electrical switch control, 12V			
	Blank	Without port relief valve			
	QQ	Plug, without relief valve (port relief valve can be added)			
End element	⑪ LS unload	LZ	Without LS unload function		
		LA	With LS unload function		
	⑫ Pilot pressure supply	X	Internal pilot pressure supply		
Y		External pilot pressure supply			
Others	⑬ Sealing type	V	FKM		
		N	NBR		
*	⑭ Design code	001			
		Blank	Without special requirement	-450	Without aluminum material
	⑮ Special application	Blank	Without special requirement	-450	Without aluminum material
	* Other request	Further requirement in the clear text			

Hydraulic diagram

· EHV 09P

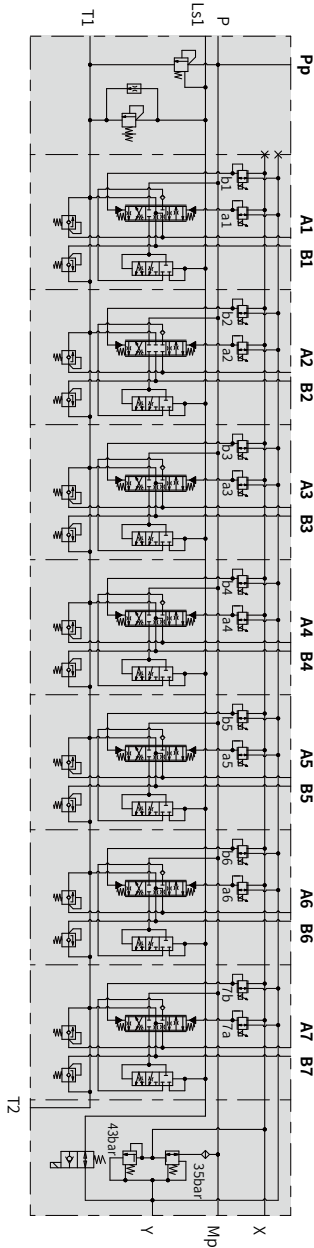

Inlet block

- Unload valve
- LS relief valve
- LS constant flow valve

Middle blocks

End block

- LS unload valve
- Pressure reducing valve

If need to adjust the order of the blocks, please consult us.

Unit dimensions

• EHV 09P

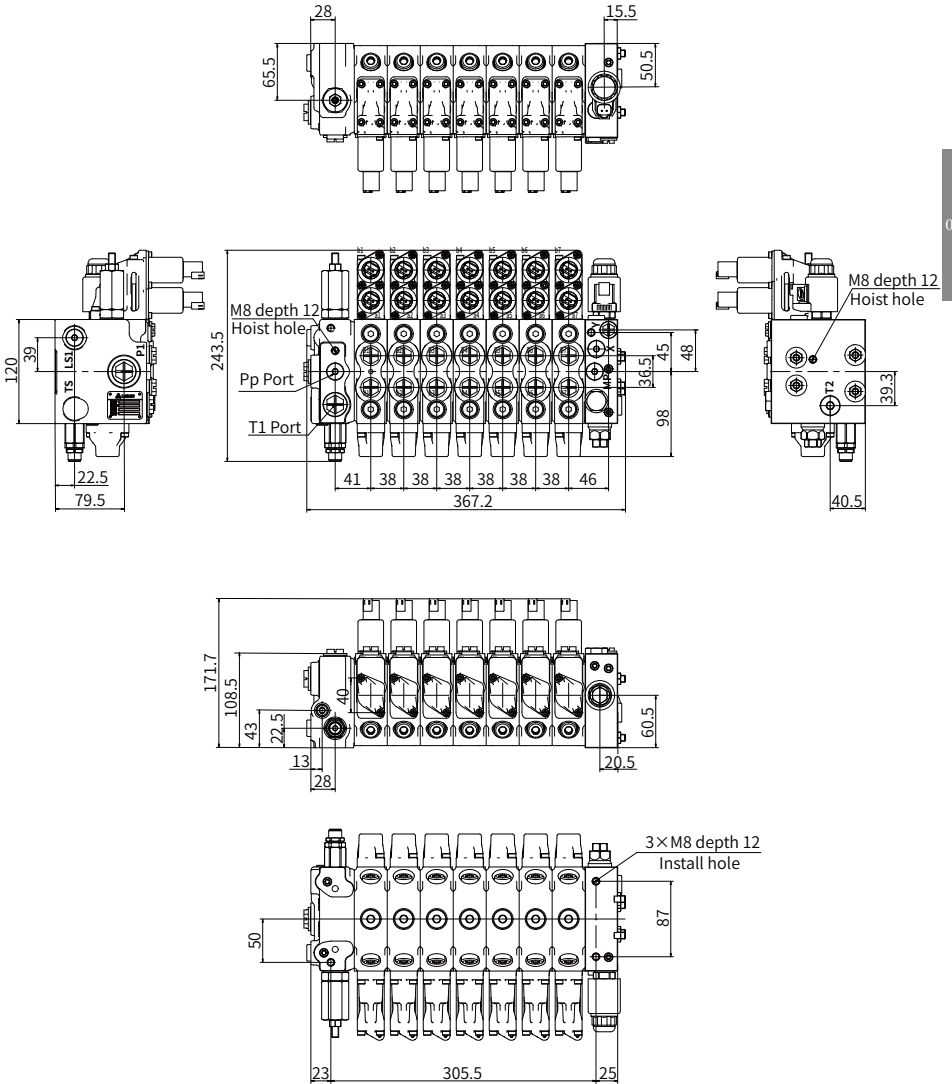

01

Inlet section assembly

· EHV 09P/09S

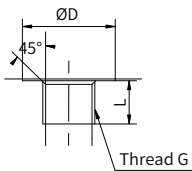
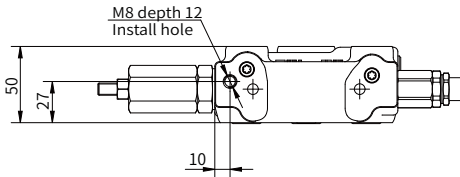
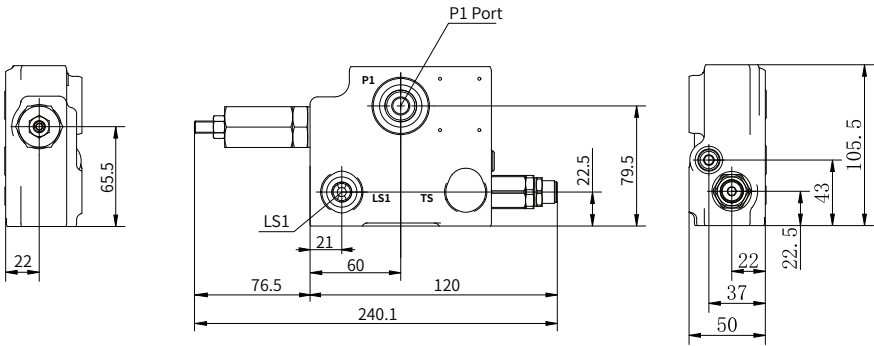
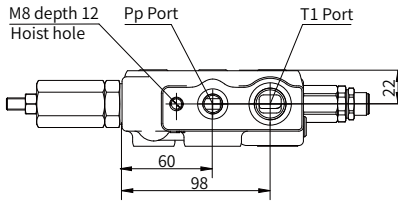

Port dimension

P1 port: G1/2

T1 port: G1/2

LS port: G1/4

Thread dimensions

G1/2: ØD 28 L 15

G1/4: ØD 20 L 12.5

Middle section assembly

· EHV 09P

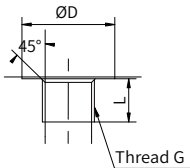
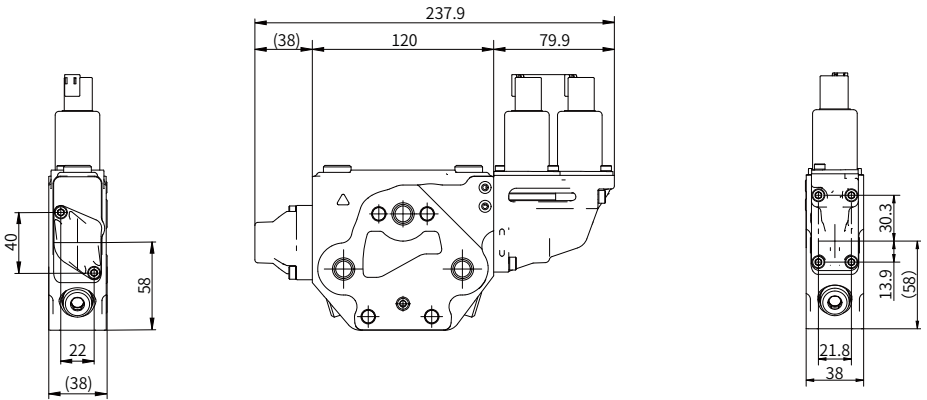
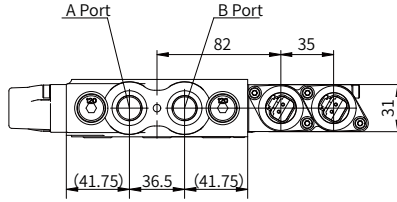

Port dimension

A/B port: G3/8 or G1/2

Thread dimensions.

G3/8: ØD 23 L 12.5

G1/2: ØD 28 L 15

Middle section assembly

· EHV 09S

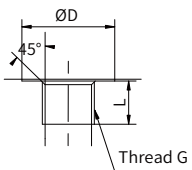
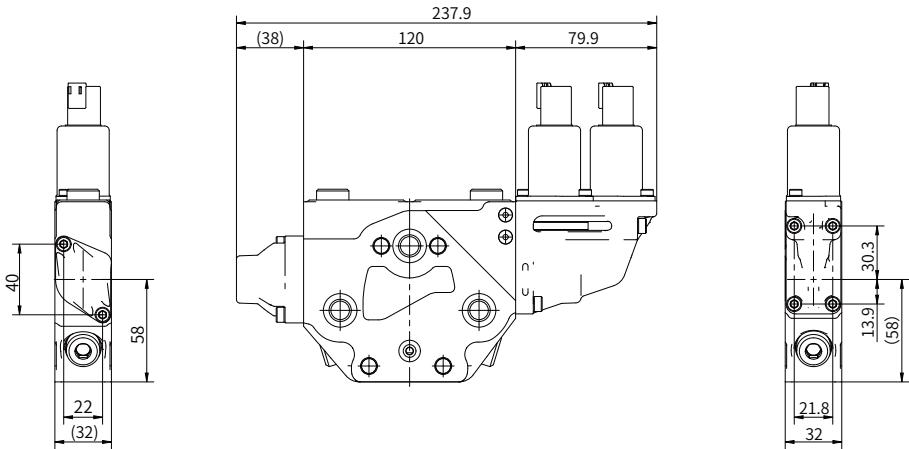
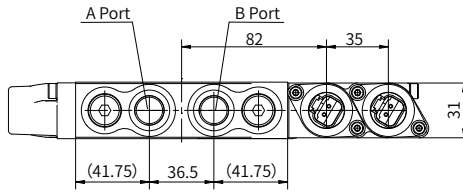

Port dimension

A/B port: G3/8 or G1/2

Thread dimensions.

G3/8: ΦD 23 L 12.5

G1/2: ΦD 28 L 15

Middle section assembly (With holding valve)

• EHV 09S

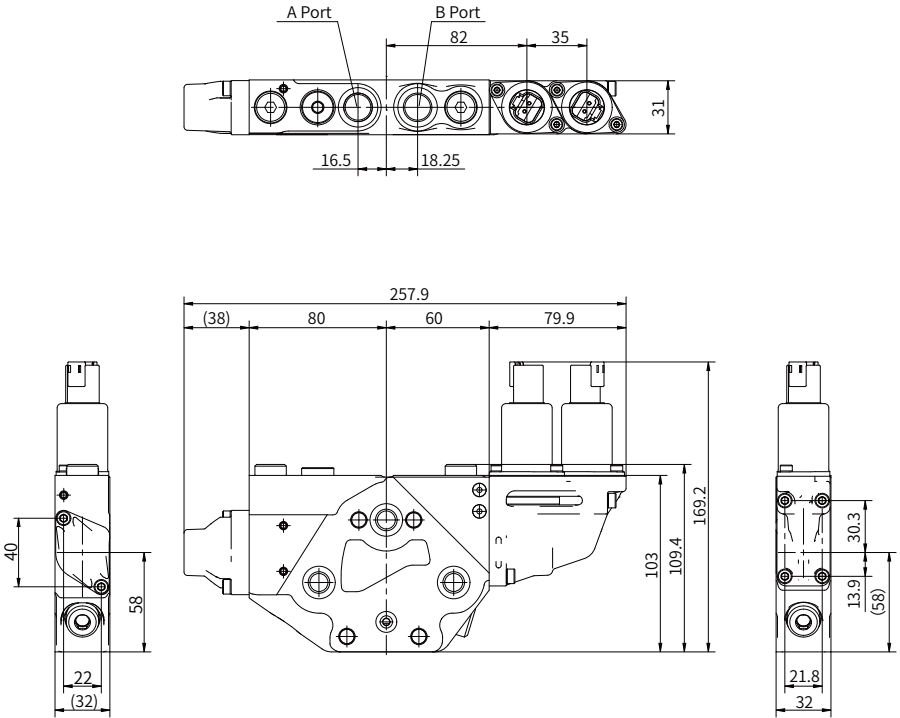

01

Port dimension

A/B port: G3/8 or G1/2

Thread dimensions.

G3/8: ΦD 23 L 12.5

G1/2: ΦD 28 L 15

Endlet section assembly

· EHV 09P/09S

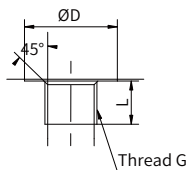
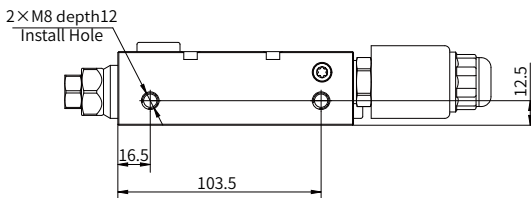
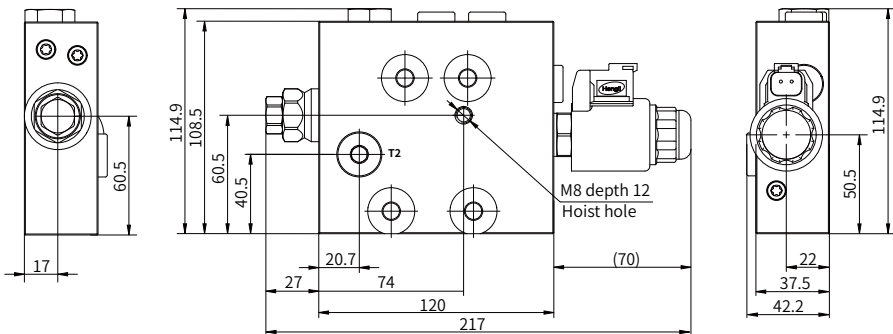
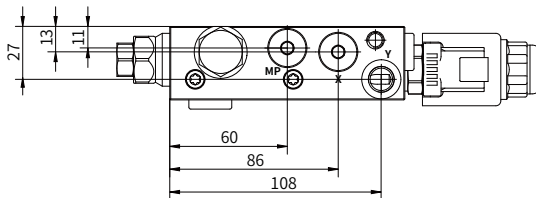

Port dimension

T2 port: G1/2
X, Y, MP port : G1/4

Thread dimensions

G1/2: Φ D 28 L 15
G1/4: Φ D 20 L 12.5

Hydraulic diagram

· EHV 18

- Unload valve
- LS relief valve
- LS constant flow valve

Inlet block



End block



Inlet block

Middle blocks

End block

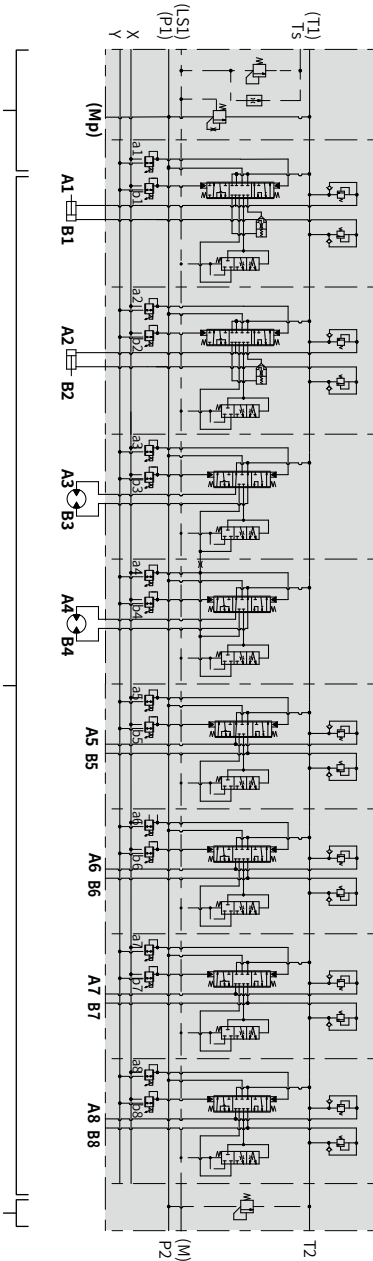

If need to adjust the order of the blocks, please consult us.

Unit dimensions

· EHV 18

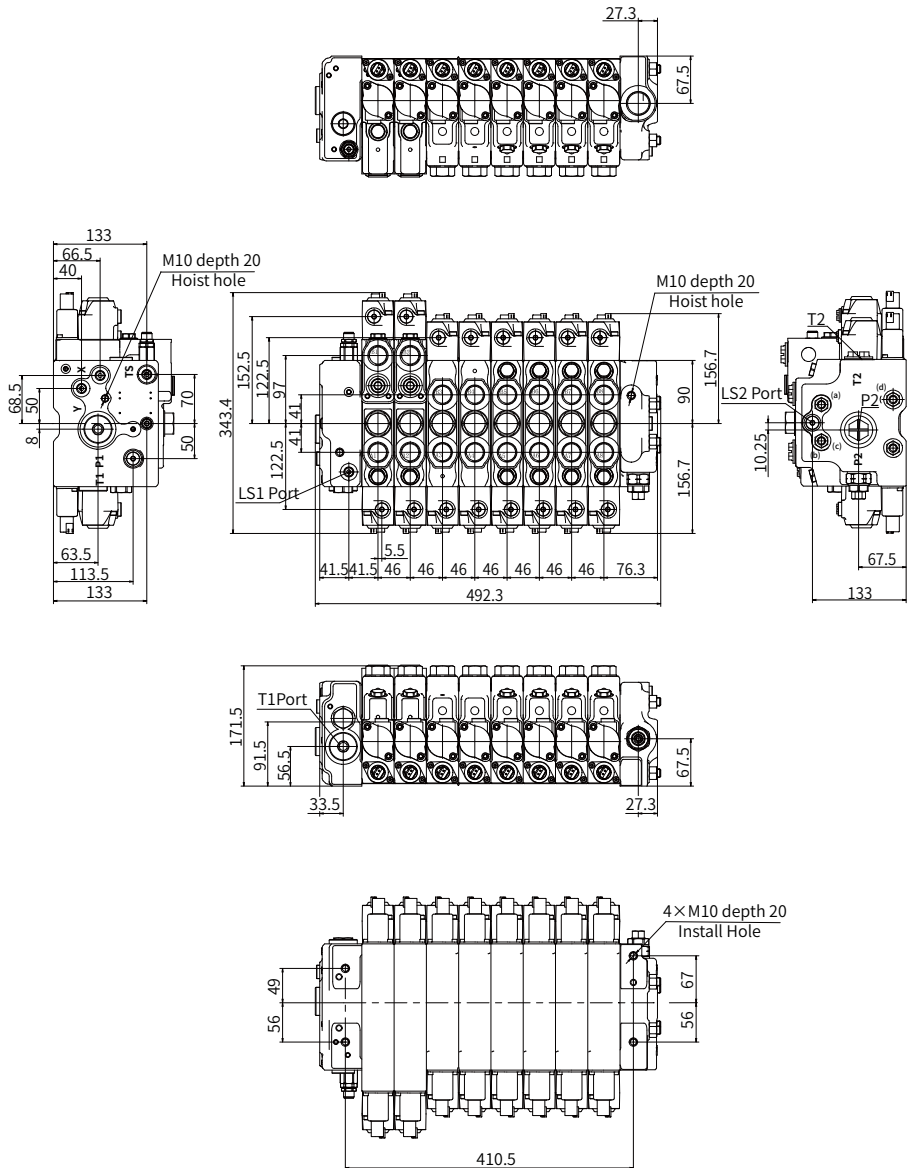

Inlet section assembly

• EHV 18

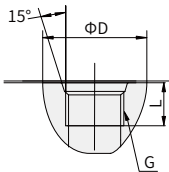
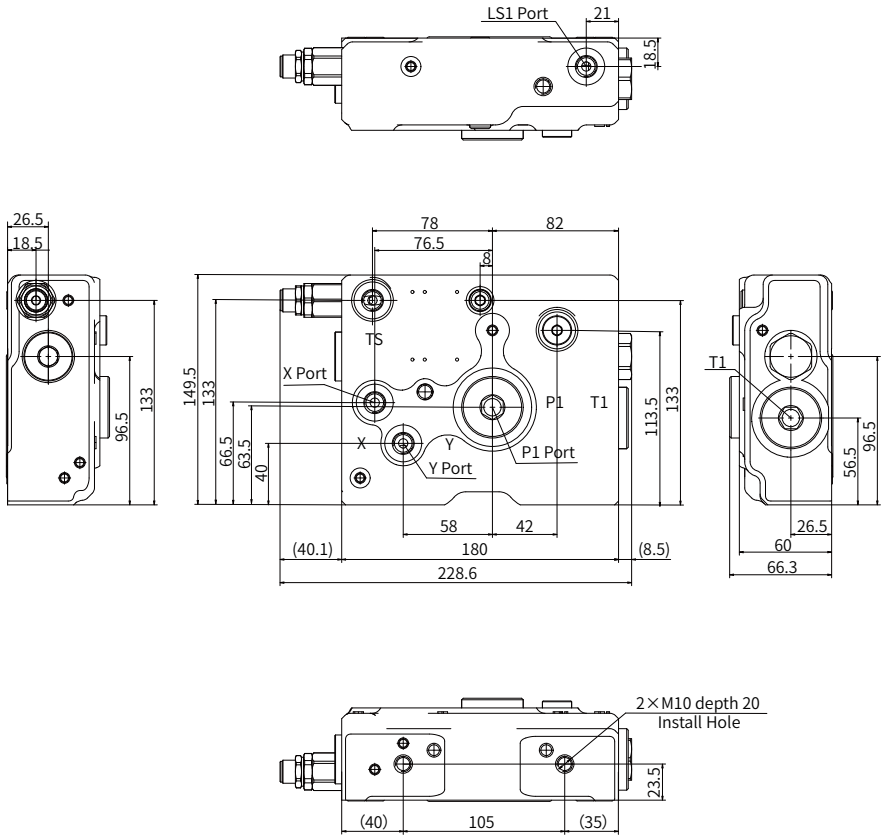

Port dimension

P port: G1
 T port: G1
 LS1, TS port: G1/4
 X, Y, MP port: G1/4

Thread dimensions

G1: ΦD 51 L 21
 G1/4: ΦD 24 L 12

Middle section assembly

· EHV 18

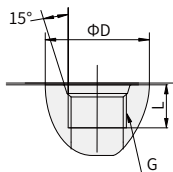
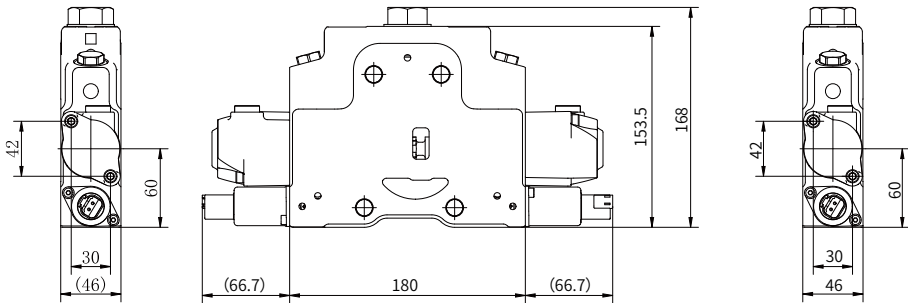
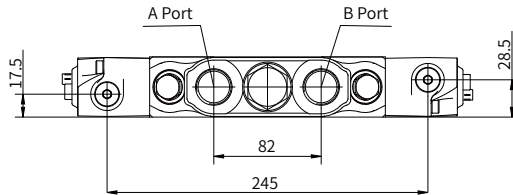

Port dimension

A/B port: G3/4

Thread dimensions

G3/4: ΦD 45 L 20

Middle section assembly (With holding valve)

• EHV 18

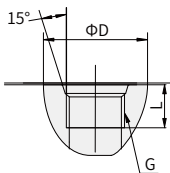
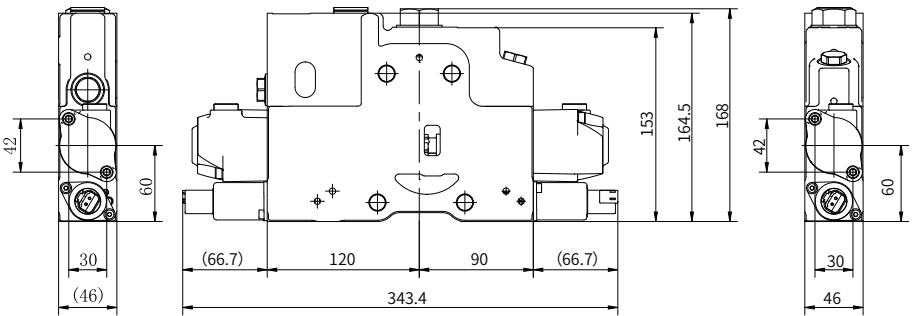
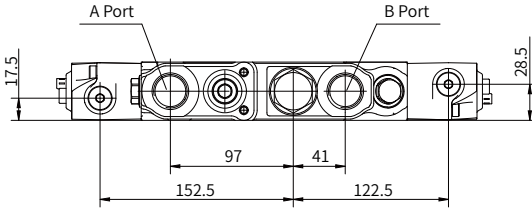

Port dimension

A/B port: G3/4

Thread dimensions

G3/4: ΦD 45 L 20

Endlet section assembly (With main pressure relief valve)

· EHV 18

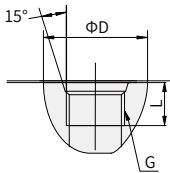
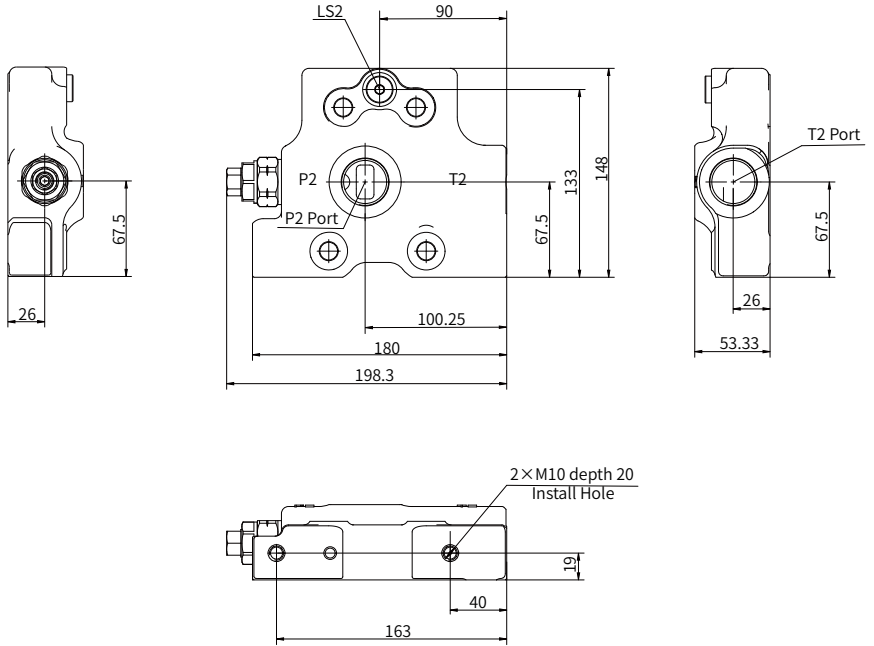

Port dimension

P2, T2 port: G1

LS2 port: G1/4

Thread dimensions

G1: ΦD 51 L 21

G1/4: ΦD 24 L 12

Endlet section assembly (With pressure reducing valve)

• EHV 18

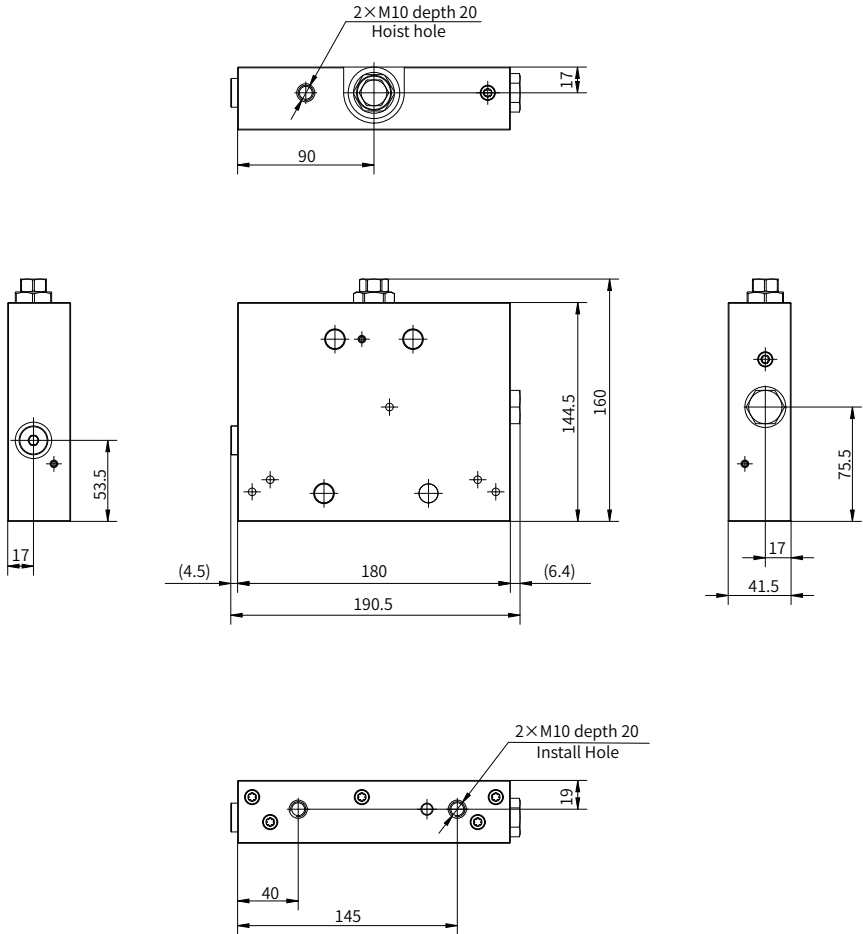

01

China

+86 400 101 8889

America

+01 630 995 3674

Germany

+49 (30) 72088-0

Japan

+81 03 6809 1696



© This brochure can be reproduced, edited, reproduced or transmitted electronically without the authorization of Hengli Hydraulic Company. Due to the continuous development of the product, the information in this brochure is not specific to the specific conditions or applicability of the industry, thus, Hengli does not take any responsibility for any incomplete or inaccurate description.